



Mathematical Aspects of Object-Oriented Modeling and Simulation

*5th International Modelica Conference
Wien*

Bernhard Bachmann
University of Applied Sciences
Bielefeld

Outline



- **Continuous system simulation**
 - Introductory example
 - Symbolic transformation
 - Efficiency issues and non-linearities
 - Higher index problems
 - Initialization
 - Numerical issues
- **Mixed system simulation**
 - Event handling
 - State events \Leftrightarrow time events
 - Symbolic transformation
 - Ideal components
 - Varying higher index problems
 - Efficiency and numerical issues

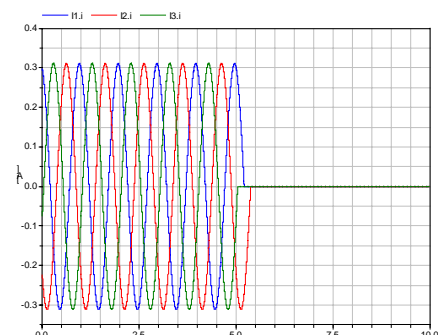
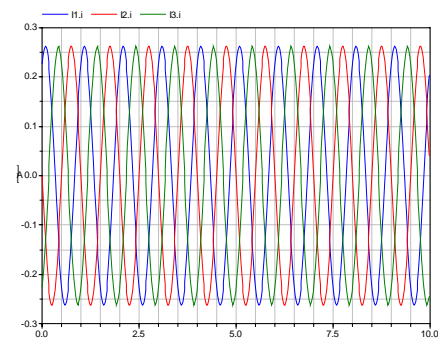

Introductory Example

- Flat model description
 - Differential equations, algebraic equations
 - Parameters, constants, and continuous variables
- Mathematical formalism
 - Differential-algebraic equations (DAEs)
 - Principles of numerical solution methods
 - Same number of equations and unknowns
 - Basic transformation steps
 - Explicit state-space representation
- Hierarchical modeling
 - Local description by equations
 - Connection equations describe interaction
 - Elimination of trivial equations
 - Explicit state-space representation

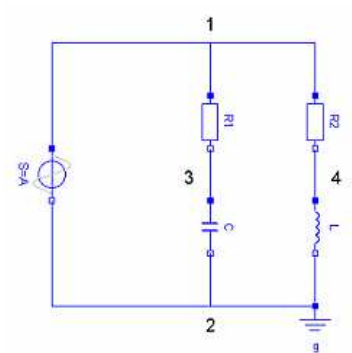

Example: A Simple Electrical System Flat Representation

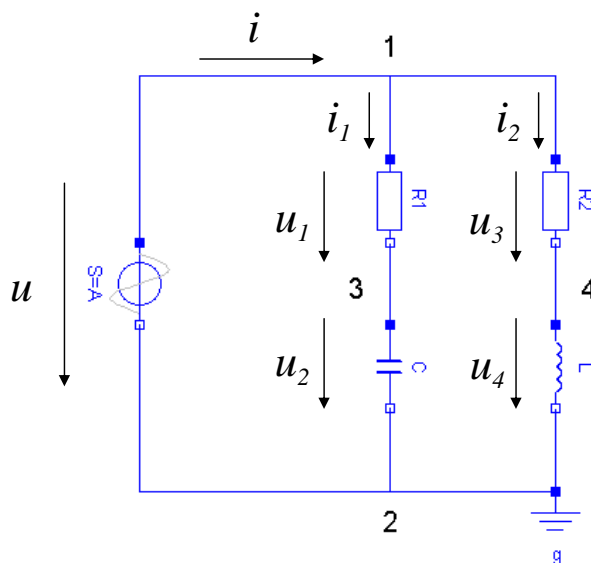

$$u = A \cdot \sin(\omega t)$$

$$u = u_1 + u_2, \quad u = u_3 + u_4$$

$$i = i_1 + i_2$$

$$u_1 = R_1 i_1, \quad u_3 = R_2 i_2,$$

$$C \frac{du_2}{dt} = i_1, \quad L \frac{di_2}{dt} = u_4$$

The dynamical behavior of the system is given by a

System of differential-algebraic equations (DAEs)

Mathematical Formalism

General representation of DAEs:

$$\underline{0} = \underline{f}(t, \underline{\dot{x}}(t), \underline{x}(t), \underline{y}(t), \underline{u}(t), \underline{p})$$

t	time
$\underline{\dot{x}}(t)$	vector of differentiated state variables
$\underline{x}(t)$	vector of state variables
$\underline{y}(t)$	vector of algebraic variables
$\underline{u}(t)$	vector of input variables
\underline{p}	vector of parameters and/or constants

Example: A Simple Electrical System

Model of the electrical system:

$$u = A \cdot \sin(\omega t + \varphi)$$

$$u = u_1 + u_2, \quad u = u_3 + u_4$$

$$i = i_1 + i_2$$

$$u_1 = R_1 i_1, \quad u_3 = R_2 i_2$$

$$C \dot{u}_2 = i_1, \quad L \dot{i}_2 = u_4$$

- 8 equations!
- Number of unknowns?
- Solution of the system?

General representation:

$$\underline{0} = \underline{f}(t, \underline{\dot{x}}(t), \underline{x}(t), \underline{y}(t), \underline{u}(t), \underline{p})$$

$$t \text{ time, } \underline{\dot{x}}(t) = \begin{pmatrix} \dot{u}_2 \\ \dot{i}_2 \end{pmatrix}, \quad \underline{x}(t) = \begin{pmatrix} u_2 \\ i_2 \end{pmatrix},$$

$$\underline{y}(t) = \begin{pmatrix} u \\ u_1 \\ u_3 \\ u_4 \\ i \\ i_1 \end{pmatrix}, \quad \underline{u}(t) \text{ not present, } \underline{p} = \begin{pmatrix} A \\ \omega \\ R_1 \\ R_2 \\ C \\ L \end{pmatrix}$$

Understand Numerical Integration Methods (Explicit Euler Method)

Integration of explicit ordinary differential equations (ODEs):

$$\dot{\underline{x}}(t) = \underline{f}(t, \underline{x}(t), \underline{u}(t), \underline{p}), \quad \underline{x}(t_0) = \underline{x}_0$$

Numerical approximation of the derivative and/or right-hand-side:

$$\dot{\underline{x}}(t_n) \approx \frac{\underline{x}(t_{n+1}) - \underline{x}(t_n)}{t_{n+1} - t_n} \approx \underline{f}(t_n, \underline{x}(t_n), \underline{u}(t_n), \underline{p})$$

Iteration scheme:

$$\underline{x}(t_{n+1}) \approx \underline{x}(t_n) + (t_{n+1} - t_n) \cdot \underline{f}(t_n, \underline{x}(t_n), \underline{u}(t_n), \underline{p})$$

Calculating an approximation of $\underline{x}(t_{n+1})$ based on the values of $\underline{x}(t_n)$

Here:
Explicit Euler integration method

Convergence?

Basic Transformation Steps

Transformation to explicit state-space representation:

$$\begin{array}{ccc}
 \underline{0} = \underline{f}(t, \dot{\underline{x}}(t), \underline{x}(t), \underline{y}(t), \underline{u}(t), \underline{p}) & \nearrow & \underline{z}(t) = \begin{pmatrix} \dot{\underline{x}}(t) \\ \underline{y}(t) \end{pmatrix} = \underline{g}(t, \underline{x}(t), \underline{u}(t), \underline{p}) \\
 \downarrow & & \downarrow \\
 \underline{0} = \underline{f}(t, \underline{z}(t), \underline{x}(t), \underline{u}(t), \underline{p}), \quad \underline{z}(t) = \begin{pmatrix} \dot{\underline{x}}(t) \\ \underline{y}(t) \end{pmatrix} & & \begin{array}{l} \dot{\underline{x}}(t) = \underline{h}(t, \underline{x}(t), \underline{u}(t), \underline{p}) \\ \underline{y}(t) = \underline{k}(t, \underline{x}(t), \underline{u}(t), \underline{p}) \end{array}
 \end{array}$$

Implicit function theorem:

Necessary condition for the existence of the transformation is that the following matrix is regular at the point of interest:

$$\det \left(\frac{\partial}{\partial \underline{z}} \underline{f}(t, \underline{z}(t), \underline{x}(t), \underline{u}(t), \underline{p}) \right) \neq 0$$

Example: A Simple Electrical System

Model of the electrical system:

$$\begin{aligned}
 u &= A \cdot \sin(\omega t) \\
 u &= u_1 + u_2, \quad u = u_3 + u_4, \quad i = i_1 + i_2 \\
 u_1 &= R_1 i_1, \quad u_3 = R_2 i_2 \\
 C \dot{u}_2 &= i_1, \quad L \dot{i}_2 = u_4
 \end{aligned}$$

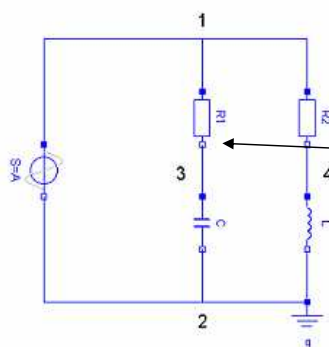

Causality!

Transformation to explicit state space representation:

$$\begin{aligned}
 u &= A \cdot \sin(\omega t) \\
 u_3 &= R_2 i_2 \\
 u_1 &= u - u_2 \\
 u_4 &= u - u_3 \\
 i_1 &= u_1 / R_1 \\
 i &= i_1 + i_2 \\
 \dot{u}_2 &= i_1 / C \\
 \dot{i}_2 &= u_4 / L
 \end{aligned}$$

Transformed Simulation Model

Model of the electrical system in explicit state space representation:

$$\begin{aligned}
 u &= A \cdot \sin(\omega t) \\
 u_3 &= R_2 i_2 \\
 u_1 &= u - u_2 \\
 u_4 &= u - u_3 \\
 i_1 &= u_1 / R_1 \\
 i &= i_1 + i_2 \\
 \dot{u}_2 &= i_1 / C \\
 \dot{i}_2 &= u_4 / L
 \end{aligned}$$

General representation:

$$\dot{\underline{x}}(t) = \underline{h}(t, \underline{x}(t), \underline{u}(t), \underline{p})$$

$$\underline{y}(t) = \underline{k}(t, \underline{x}(t), \underline{u}(t), \underline{p})$$

$$\begin{pmatrix} \dot{u}_2(t) \\ \dot{i}_2(t) \end{pmatrix} = \underline{h} \left(t, \underbrace{u_2(t), i_2(t)}_{\text{states}}, \underbrace{A, \omega, R_1, R_2, C, L}_{\text{parameters/constants}} \right)$$

$$\begin{pmatrix} u(t) \\ u_1(t) \\ u_3(t) \\ u_4(t) \\ i(t) \\ i_1(t) \end{pmatrix} = \underline{k} \left(t, \underbrace{u_2(t), i_2(t)}_{\text{states}}, \underbrace{A, \omega, R_1, R_2, C, L}_{\text{parameters/constants}} \right)$$

Hierarchical Object-Oriented Modeling

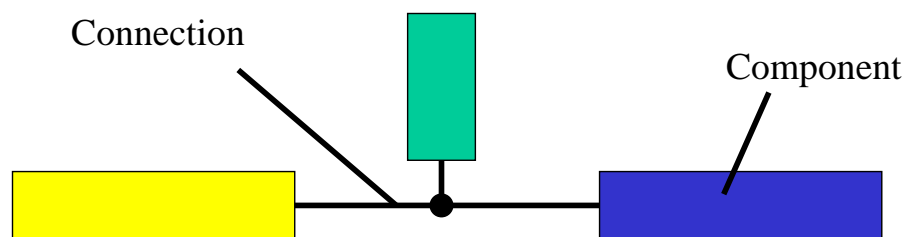

- Each icon represents a physical component
 - Electrical resistor, mechanical gearbox, pump
- Composition lines are the actual physical connections
 - Electrical line, mechanical connection, heat flow between two components
- Variables at the interfaces describe interaction with other components
- Physical behavior of a component is described by equations
- Hierarchical decomposition of components

Hierarchical Model of the Electrical System

Resistor		$0 = i_1 + i_2$ $u = v_1 - v_2$ $u = R i_1$
Capacitor		$0 = i_1 + i_2$ $u = v_1 - v_2$ $i_1 = C du/dt$
Inductor		$0 = i_1 + i_2$ $u = v_1 - v_2$ $u = L di_1/dt$
Voltage source		$0 = i_1 + i_2$ $u = v_1 - v_2$ $u = A \sin(\omega t)$
Ground		$v_1 = 0$

$0 = R1.i_1 + R1.i_2$ $R1.u = R1.v_1 - R1.v_2$ $R1.u = R1.R \cdot R1.i_1$	R1	$0 = R2.i_1 + R2.i_2$ $R2.u = R2.v_1 - R2.v_2$ $R2.u = R2.R \cdot R2.i_1$	R2
$0 = C.i_1 + C.i_2$ $C.u = C.v_1 - C.v_2$ $C.i_1 = C.C \cdot dC.u/dt$	C	$0 = L.i_1 + L.i_2$ $L.u = L.v_1 - L.v_2$ $L.u = L.L \cdot dL.i_1/dt$	L
$0 = S.i_1 + S.i_2$ $S.u = S.v_1 - S.v_2$ $S.u = S.A \sin(S.w \cdot t)$	S	$g.v_1 = 0$	g
$S.v_1 = R1.v_1$ $S.v_1 = R2.v_1$ $0 = S.i_1 + R1.i_1 + R2.i_1$	1	$R1.v_2 = C.v_1$ $0 = R1.i_2 + C.i_1$	3
$g.v_1 = C.v_2$ $g.v_1 = L.v_2$ $g.v_1 = S.v_2$ $0 = g.i_1 + C.i_2 + L.i_2 + S.i_2$	2	$R2.v_2 = L.v_1$ $0 = R2.i_2 + L.i_1$	4

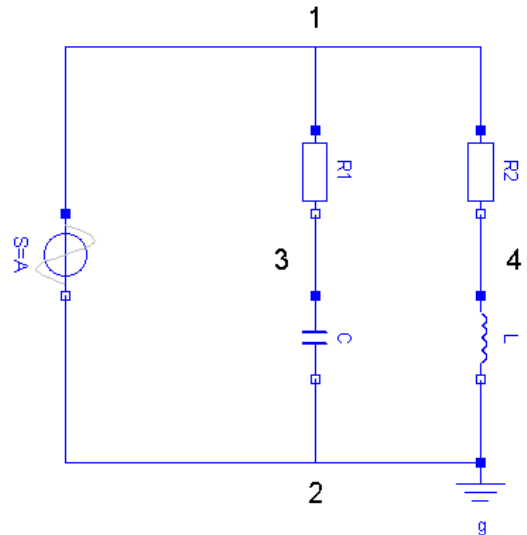

- 27 equations!
- number of unknowns?
- many trivial equations!

Transformation to explicit state space representation with elimination of trivial equations and further simplifications

$$\begin{aligned}
 R1.v_1 &:= S.A \cdot \sin(S.w \cdot t) \\
 R2.u &:= R2.R \cdot L.i_1 \\
 R1.u &:= R1.v_1 - C.u \\
 L.u &:= R1.v_1 - R2.u \\
 C.i_1 &:= R1.u / R1.R \\
 S.i_1 &:= C.i_1 + L.i_1 \\
 dC.u/dt &:= C.i_1 / C.C \\
 dL.i_1/dt &:= L.u / L.L
 \end{aligned}$$

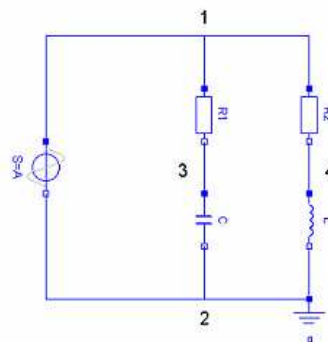
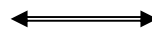

$$\begin{aligned}
 u &= A \cdot \sin(\omega t) \\
 u_3 &= R_2 i_2 \\
 u_1 &= u - u_2 \\
 u_4 &= u - u_3 \\
 i_1 &= u_1 / R_1 \\
 i &= i_1 + i_2 \\
 \dot{u}_2 &= i_1 / C \\
 \dot{i}_2 &= u_4 / L
 \end{aligned}$$

Symbolic Transformation

Algorithmic Steps

- **DAEs and bipartite graph representation**
 - Structural representation of the equation system
- **The matching problem**
 - Assign to each variable exact one equation
 - Same number of equations and unknowns
- **Construct a directed graph**
 - Find sinks, sources and strong components
 - Sorting the equation system
- **Adjacence Matrix and structural regularity**
 - Block-lower triangular form (BLT-Transformation)

$$\underline{0} = \underline{f}(t, \dot{\underline{x}}(t), \underline{x}(t), \underline{y}(t), \underline{u}(t), \underline{p})$$



$$\underline{0} = \underline{f}(t, \underline{z}(t), \underline{x}(t), \underline{u}(t), \underline{p}), \quad \underline{z}(t) = \begin{pmatrix} \dot{\underline{x}}(t) \\ \underline{y}(t) \end{pmatrix}$$



$$\underline{z}(t) = \begin{pmatrix} \dot{\underline{x}}(t) \\ \underline{y}(t) \end{pmatrix} = \underline{g}(t, \underline{x}(t), \underline{u}(t), \underline{p})$$



$$\dot{\underline{x}}(t) = \underline{h}(t, \underline{x}(t), \underline{u}(t), \underline{p})$$

$$\underline{y}(t) = \underline{k}(t, \underline{x}(t), \underline{u}(t), \underline{p})$$

DAEs and Bipartite Graph Representation

Example of a regular DAE:

$$\underline{0} = \underline{f}(t, \underline{z}(t), \underline{x}(t), \underline{u}(t), \underline{p}), \quad \underline{z}(t) = \begin{pmatrix} \dot{\underline{x}}(t) \\ \underline{y}(t) \end{pmatrix}$$

$$\begin{aligned} f_1(z_3, z_4) &= 0 \\ f_2(z_2) &= 0 \\ f_3(z_2, z_3, z_5) &= 0 \\ f_4(z_1, z_2) &= 0 \\ f_5(z_1, z_3, z_5) &= 0 \end{aligned}$$

Bipartite graph

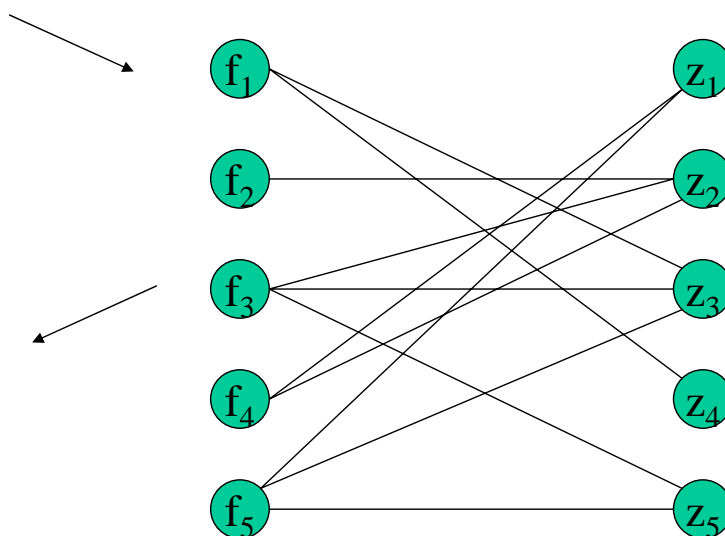

Adjacence matrix

$$\begin{matrix} & z_1 & z_2 & z_3 & z_4 & z_5 \\ \begin{matrix} f_1 \\ f_2 \\ f_3 \\ f_4 \\ f_5 \end{matrix} & \begin{pmatrix} 0 & 0 & 1 & 1 & 0 \\ 0 & 1 & 0 & 0 & 0 \\ 0 & 1 & 1 & 0 & 1 \\ 1 & 1 & 0 & 0 & 0 \\ 1 & 0 & 1 & 0 & 1 \end{pmatrix} \end{matrix}$$

Solve the Matching Problem

Example of a regular DAE:

$$\begin{aligned}
 f_1(z_3, z_4) &= 0 \\
 f_2(z_2) &= 0 \\
 f_3(z_2, z_3, z_5) &= 0 \\
 f_4(z_1, z_2) &= 0 \\
 f_5(z_1, z_3, z_5) &= 0
 \end{aligned}$$

	z_1	z_2	z_3	z_4	z_5
f_1	0	0	1	1	0
f_2	0	1	0	0	0
f_3	0	1	1	0	1
f_4	1	1	0	0	0
f_5	1	0	1	0	1

Bipartite graph

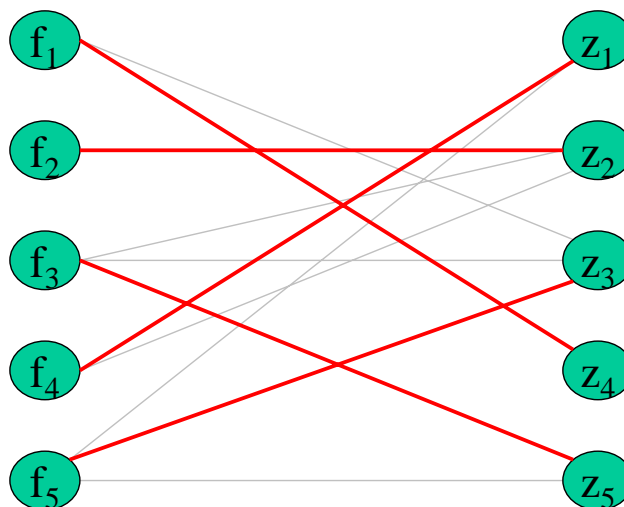

Construct a Directed Graph

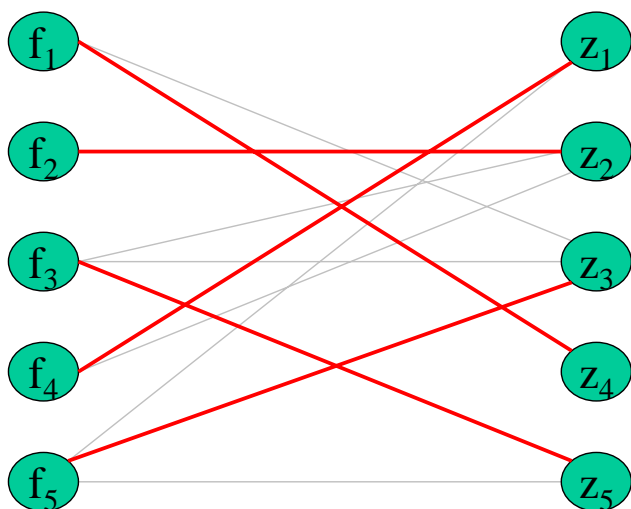

Construct a Directed Graph

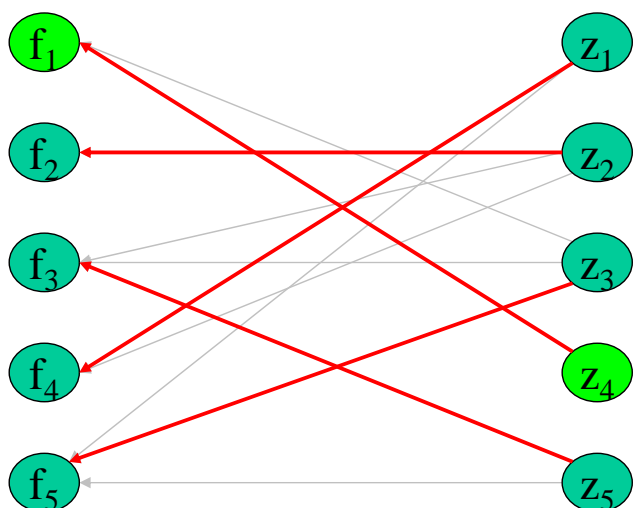

Construct a Directed Graph

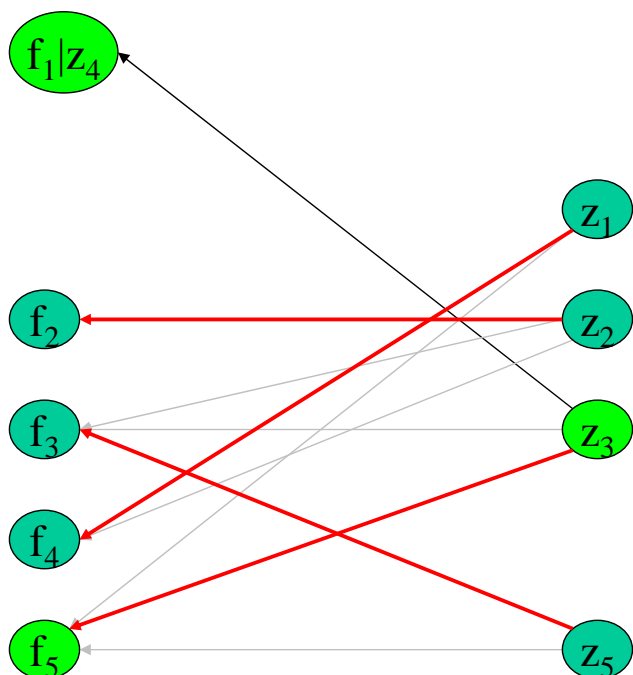

Construct a Directed Graph

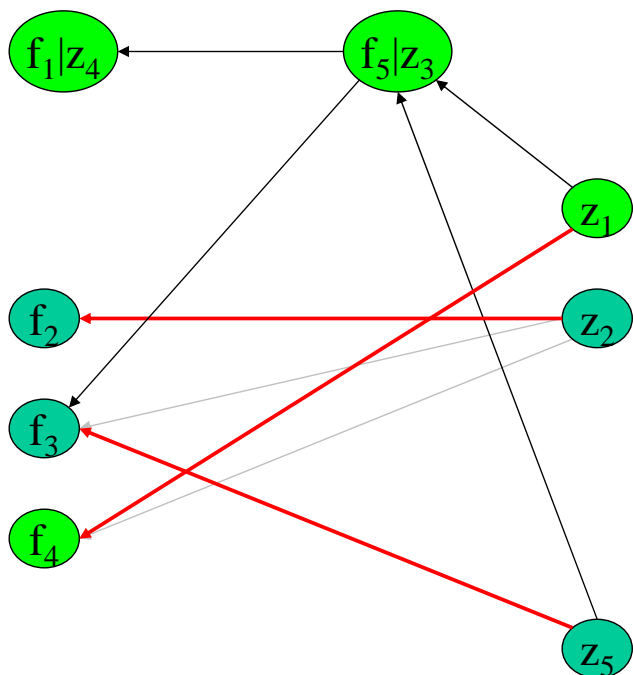

Construct a Directed Graph

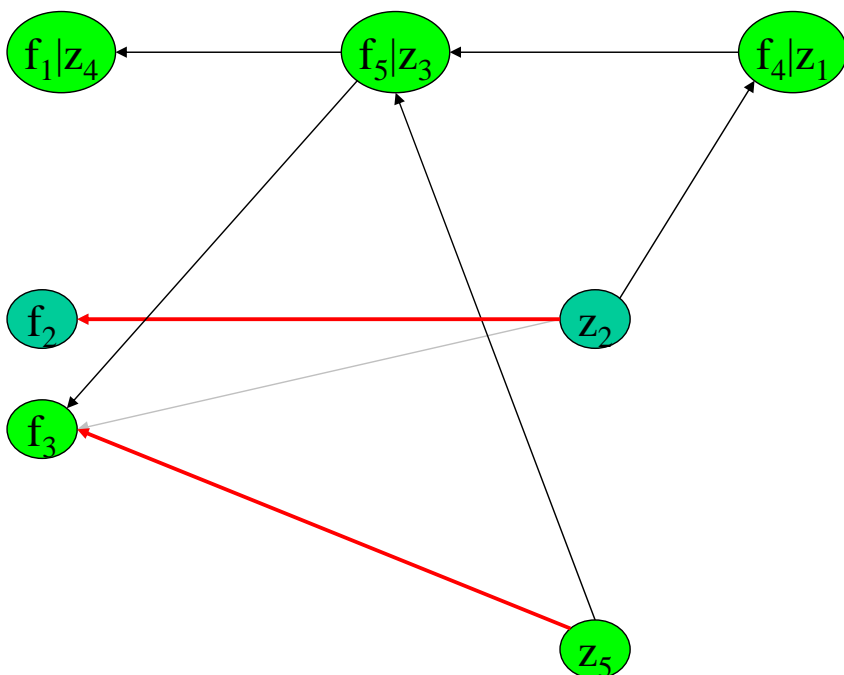

Construct a Directed Graph

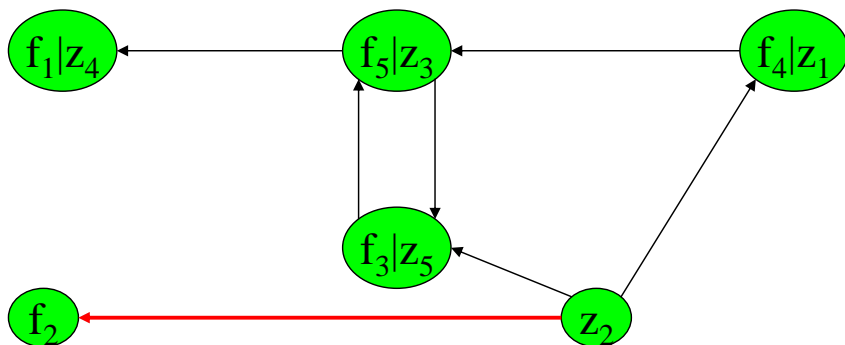

Construct a Directed Graph

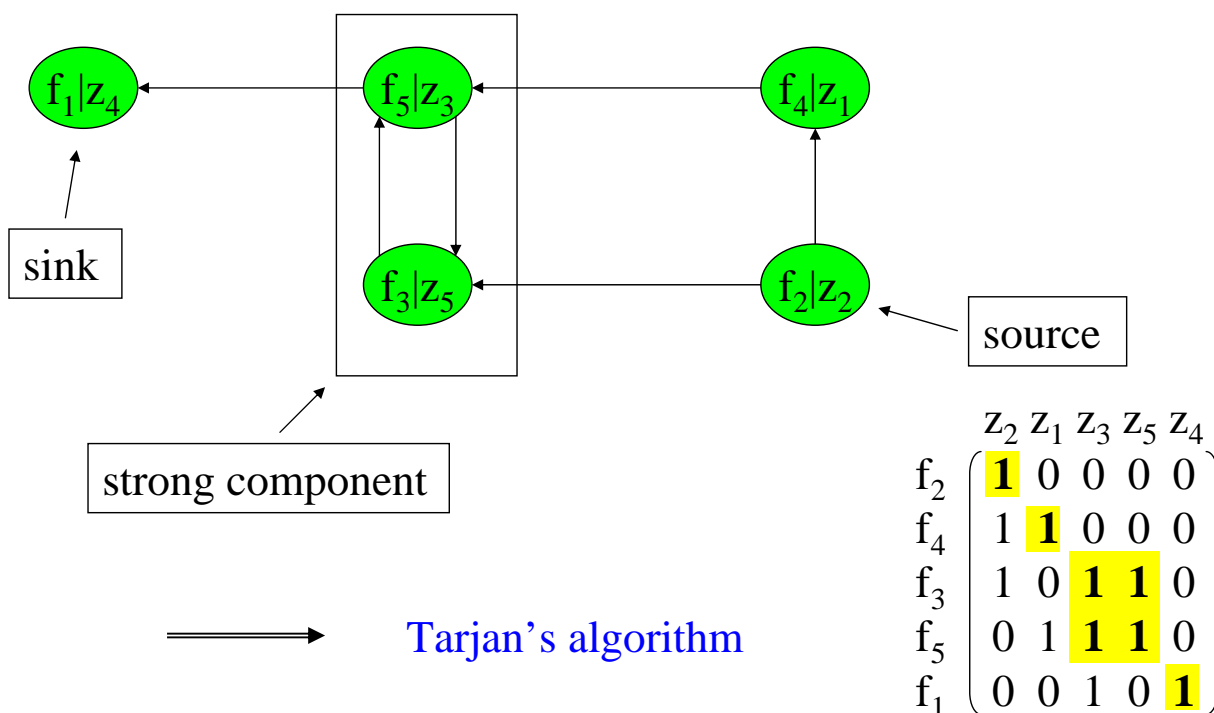

Transformation Algorithms and the BLT-Form (Block-Lower-Triangle Form)

Example of a regular DAE:

$$\begin{array}{lll}
 f_1(z_3, z_4) = 0 & f_1(z_3, [z_4]) = 0 & f_2(z_2) = 0 \\
 f_2(z_2) = 0 & f_2([z_2]) = 0 & f_4(z_1, z_2) = 0 \\
 f_3(z_2, z_3, z_5) = 0 & f_3(z_2, z_3, [z_5]) = 0 & f_3(z_2, z_3, z_5) = 0 \\
 f_4(z_1, z_2) = 0 & f_4([z_1], z_2) = 0 & f_5(z_1, z_3, z_5) = 0 \\
 f_5(z_1, z_3, z_5) = 0 & f_5(z_1, [z_3], z_5) = 0 & f_1(z_3, z_4) = 0
 \end{array}$$

BLT-form of the adjacency matrix

$$\begin{array}{l}
 f_1 \\
 f_2 \\
 f_3 \\
 f_4 \\
 f_5
 \end{array}
 \begin{pmatrix}
 z_1 & z_2 & z_3 & z_4 & z_5 \\
 0 & 0 & 1 & 1 & 0 \\
 0 & 1 & 0 & 0 & 0 \\
 0 & 1 & 1 & 0 & 1 \\
 1 & 1 & 0 & 0 & 0 \\
 1 & 0 & 1 & 0 & 1
 \end{pmatrix}$$

2006-09-04
B. Bachmann, FH Bielefeld

$$\begin{array}{l}
 f_1 \\
 f_2 \\
 f_3 \\
 f_4 \\
 f_5
 \end{array}
 \begin{pmatrix}
 z_1 & z_2 & z_3 & z_4 & z_5 \\
 0 & 0 & 1 & \mathbf{1} & 0 \\
 0 & \mathbf{1} & 0 & 0 & 0 \\
 0 & 1 & 1 & 0 & \mathbf{1} \\
 \mathbf{1} & 1 & 0 & 0 & 0 \\
 1 & 0 & \mathbf{1} & 0 & 1
 \end{pmatrix}$$

Mathematical Aspects of Object-Oriented
Modeling and Simulation

$$\begin{array}{l}
 f_2 \\
 f_4 \\
 f_3 \\
 f_5 \\
 f_1
 \end{array}
 \begin{pmatrix}
 z_2 & z_1 & z_3 & z_5 & z_4 \\
 \mathbf{1} & 0 & 0 & 0 & 0 \\
 1 & \mathbf{1} & 0 & 0 & 0 \\
 1 & 0 & \mathbf{1} & \mathbf{1} & 0 \\
 0 & 1 & \mathbf{1} & \mathbf{1} & 0 \\
 0 & 0 & 1 & 0 & \mathbf{1}
 \end{pmatrix}$$

25

Structural Regularity of the Adjacency Matrix

- Transformation algorithm works on the model structure
 - Assign each variable to exact one equation (matching problem)
 - Find equations which have to be solved simultaneously
- Nevertheless, certain parameter settings could make a model singular

model singular

$$\Leftrightarrow \begin{vmatrix} a & b \\ 1 & 1 \end{vmatrix} = a - b = 0$$

$$\Leftrightarrow a = b$$

```

model SingularModel
  parameter Real a=2;
  parameter Real b=1;
  Real x, y;
  equation
    a*der(x) + b*der(y) = sin(time);
    der(x) + der(y) = cos(time);
end SingularModel
    
```

Example: A Simple Electrical System

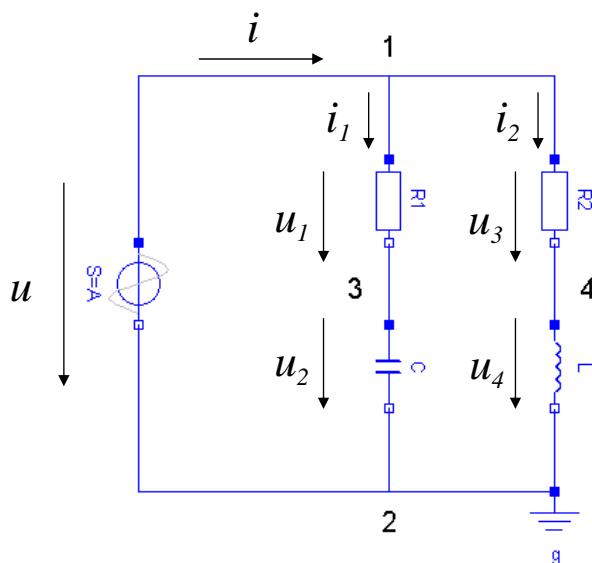

$$\underline{u} = A \cdot \sin(\omega t)$$

$$u = \underline{u}_1 + \underline{u}_2$$

$$\underline{u}_3 = R_2 \underline{i}_2$$

$$u = u_3 + \underline{u}_4$$

$$u_1 = R_1 \underline{i}_1$$

$$\underline{i} = \underline{i}_1 + \underline{i}_2$$

$$C \frac{d\underline{u}_2}{dt} = \underline{i}_1$$

$$L \frac{d\underline{i}_2}{dt} = u_4$$

Efficiency Issues and Non-Linear Equations

Transformed equation system

- Efficient calculation of the unknowns and derivatives of the states
- Solve single linear equations based on causality

Algebraic loops

- Linear equation systems can be treated by direct or iterative routines
- Non-linear equation systems need more sophisticated solution techniques (only local convergence!)

Real-time aspects

- Causality of non-linear equation may influence the runtime efficiency

$$\underline{0} = \underline{f}(t, \dot{\underline{x}}(t), \underline{x}(t), \underline{y}(t), \underline{u}(t), \underline{p})$$

↓

$$\underline{0} = \underline{f}(t, \underline{z}(t), \underline{x}(t), \underline{u}(t), \underline{p}), \quad \underline{z}(t) = \begin{pmatrix} \dot{\underline{x}}(t) \\ \underline{y}(t) \end{pmatrix}$$

↓

$$\underline{z}(t) = \begin{pmatrix} \dot{\underline{x}}(t) \\ \underline{y}(t) \end{pmatrix} = \underline{g}(t, \underline{x}(t), \underline{u}(t), \underline{p})$$

↓

$$\dot{\underline{x}}(t) = \underline{h}(t, \underline{x}(t), \underline{u}(t), \underline{p})$$

$$\underline{y}(t) = \underline{k}(t, \underline{x}(t), \underline{u}(t), \underline{p})$$

Example: A Non-Linear Electrical System

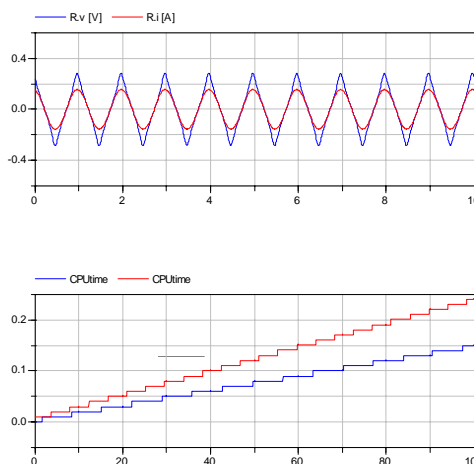
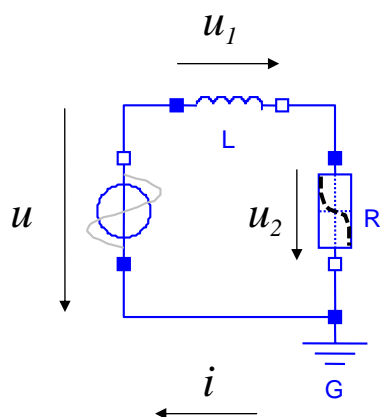

$$u = A \cdot \sin(\omega t)$$

$$i = a \tanh(b u_2)$$

$$u = u_1 + u_2$$

$$L \frac{di}{dt} = u_1$$

Re-writing the non-linear equation (Causality):

$$u_2 = \frac{1}{2b} \log \left(\frac{(1+i/a)}{(1-i/a)} \right)$$

Example: A Non-Linear Electrical System

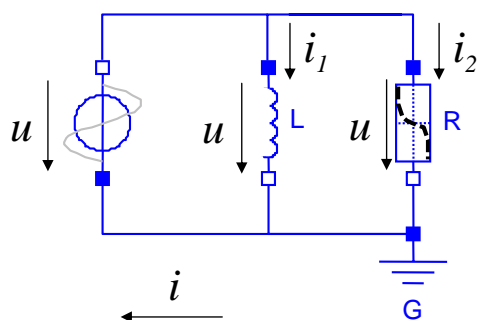

$$u = A \cdot \sin(\omega t)$$

$$i_1 = a \tanh(b u)$$

$$L \frac{di_2}{dt} = u$$

$$i = i_1 + i_2$$

Causality of the non-linear equation correct

Higher Index Problems

Structurally Singular Systems

Higher-index DAEs

- Differential index of a DAE
- Structural singularity of the adjacency matrix
- Index reduction method using symbolic differentiation of equations

$$\underline{0} = \underline{f}(t, \dot{\underline{x}}(t), \underline{x}(t), \underline{y}(t), \underline{u}(t), \underline{p})$$



$$\underline{0} = \underline{f}(t, \underline{z}(t), \underline{x}(t), \underline{u}(t), \underline{p}), \quad \underline{z}(t) = \begin{pmatrix} \dot{\underline{x}}(t) \\ \underline{y}(t) \end{pmatrix}$$



$$\underline{z}(t) = \begin{pmatrix} \dot{\underline{x}}(t) \\ \underline{y}(t) \end{pmatrix} = \underline{g}(t, \underline{x}(t), \underline{u}(t), \underline{p})$$



$$\dot{\underline{x}}(t) = \underline{h}(t, \underline{x}(t), \underline{u}(t), \underline{p})$$

$$\underline{y}(t) = \underline{k}(t, \underline{x}(t), \underline{u}(t), \underline{p})$$

Numerical issues

- Consistent initialization
- Drift phenomenon
- Dummy derivative method

State selection mechanism in Modelica

- See also initialization of 3-phase electrical system

Higher-Index-DAEs

General representation of DAEs:

$$\underline{0} = \underline{f}(t, \dot{\underline{x}}(t), \underline{x}(t), \underline{y}(t), \underline{u}(t), \underline{p})$$

t time

$\dot{\underline{x}}(t)$ vector of differentiated state variables

$\underline{x}(t)$ vector of state variables

$\underline{y}(t)$ vector of algebraic variables

$\underline{u}(t)$ vector of input variables

\underline{p} vector of parameters and/or constants

Differential index of a DAE:

The minimal number of analytical differentiations of the equation system necessary to extract by algebraic manipulations an explicit ODE for all unknowns.

DAE with differential index 0:

$$\underline{0} = \underline{f}(t, \underline{\dot{x}}(t), \underline{x}(t), \underline{u}(t), \underline{p}) \longrightarrow \underline{\dot{x}}(t) = \underline{g}(t, \underline{x}(t), \underline{u}(t), \underline{p})$$

DAE with differential index 1:

$$\underline{0} = \underline{f}(t, \underline{\dot{x}}(t), \underline{x}(t), \underline{y}(t), \underline{u}(t), \underline{p})$$

$$\downarrow$$

$$\underline{\dot{x}}(t) = \underline{h}(t, \underline{x}(t), \underline{u}(t), \underline{p}) \longrightarrow \underline{\dot{x}}(t) = \underline{h}(t, \underline{x}(t), \underline{u}(t), \underline{p})$$

$$\underline{y}(t) = \underline{k}(t, \underline{x}(t), \underline{u}(t), \underline{p}) \longrightarrow \underline{\dot{y}}(t) = \frac{d}{dt} \underline{k}(t, \underline{x}(t), \underline{u}(t), \underline{p})$$

Higher-Index-DAE Example (index 2)

$$\underline{0} = \underline{f}(t, \underline{\dot{x}}(t), \underline{x}(t), \underline{y}(t), \underline{u}(t), \underline{p})$$

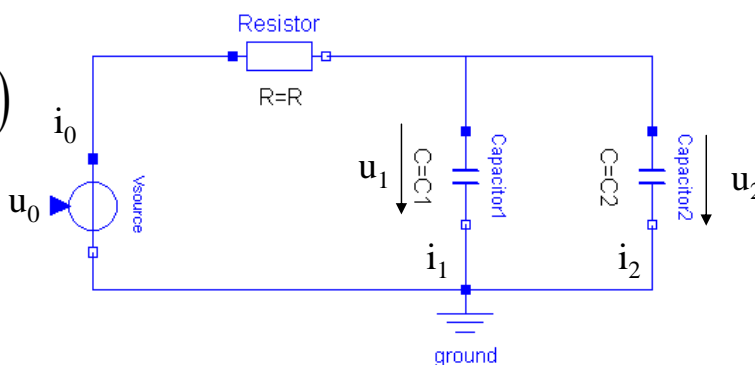

$$C_1 \cdot \dot{u}_1 = i_1$$

$$C_2 \cdot \dot{u}_2 = i_2$$

$$\boxed{u_1 = u_2}$$

$$i_0 = i_1 + i_2$$

$$u_0 = R \cdot i_0 + u_1$$

$$\mathbf{x} = \begin{bmatrix} u_1 \\ u_2 \end{bmatrix}$$

$$\mathbf{y} = \begin{bmatrix} i_0 \\ i_1 \\ i_2 \end{bmatrix}$$

$$\mathbf{z} = \begin{bmatrix} \dot{u}_1 \\ \dot{u}_2 \\ i_0 \\ i_1 \\ i_2 \end{bmatrix}$$

5 equations and 5 unknowns.
BUT: system is singular!

constrained equation
between states

Higher-Index-DAE Example (index 2)

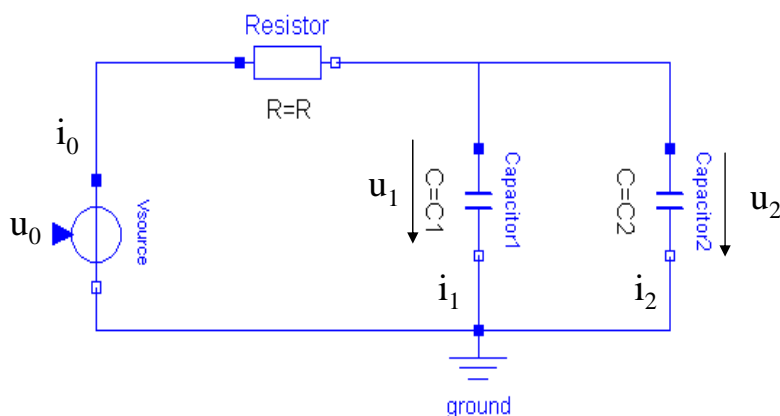

$$C_1 \cdot \dot{u}_1 = i_1$$

$$C_2 \cdot \dot{u}_2 = i_2$$

~~$$u_1 = u_2$$~~

$$i_0 = i_1 + i_2$$

$$u_0 = R \cdot i_0 + u_1$$

$$\dot{u}_1 = \dot{u}_2$$

Algorithmic steps

- Differentiation of constrained equations
- Extracting underlying ODE (DAE of index 1)

⇒ ODE with 5 equations and 5 unknowns

- Consistent initialization necessary

$$\mathbf{x} = \begin{bmatrix} u_1 \\ u_2 \end{bmatrix} \quad \mathbf{z} = \begin{bmatrix} \dot{u}_1 \\ \dot{u}_2 \\ i_0 \\ i_1 \\ i_2 \end{bmatrix}$$

Higher-Index-DAEs -- Numerical Problems

- Consistent initial conditions
 - Relation between states are eliminated when differentiating
 - Initial conditions need to be determined using the algebraic constrains
 - Automatic procedure possible using assign algorithm on the constrained equations
- Drift phenomenon
 - Algebraic constrained no longer fulfilled during simulation
 - Even worse when simulating stiff problems

⇒ Dummy-Derivative method

- Matching algorithm fails
 - System is structurally singular
 - Find minimal subset of equations
 - more equations than unknown variables
 - Singularity is due to equations constraining states

- Differentiate subset of equations
 - Static state selection during compile time
 - choose one state and corresponding derivative as purely algebraic variable
 - so-called dummy-state and dummy derivative
 - by differentiation introduced variables are algebraic
 - continue matching algorithm
 - check initial conditions
 - Dynamic state selection during simulation time
 - store information on constrained states
 - make selection dynamically based on heuristic criteria
 - new state selection triggers an event (re-initialize states)

Dummy-Derivative method Example (index 2)

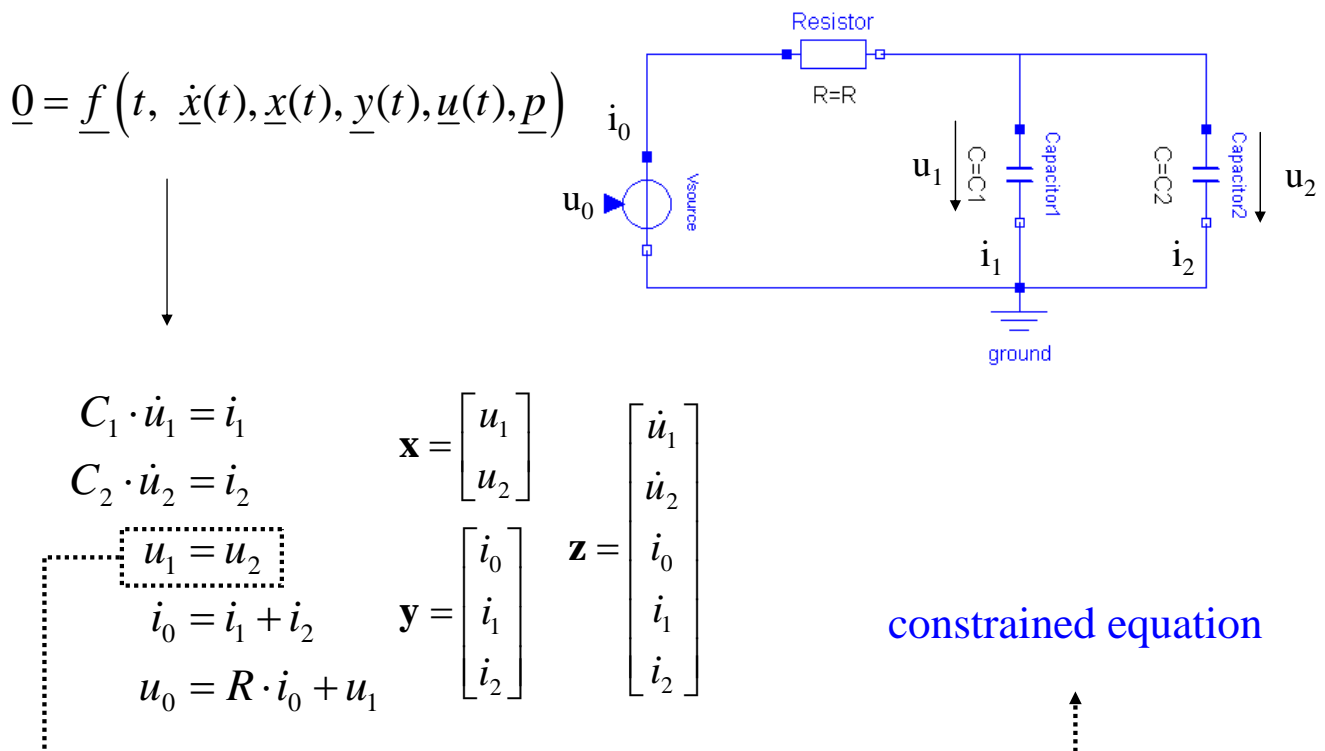

Dummy-Derivative method

Example (index 2)

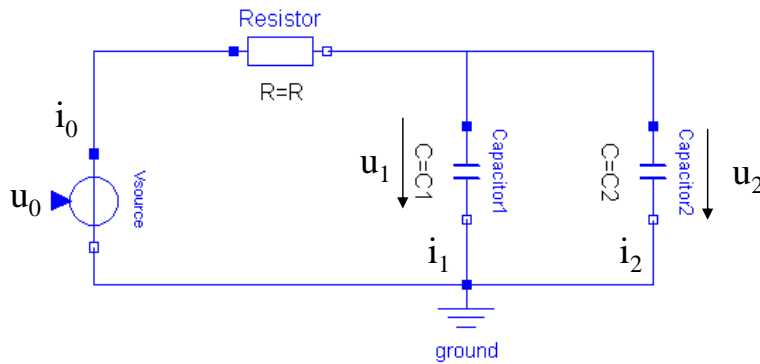

$$C_1 \cdot \dot{u}_1 = i_1$$

$$C_2 \cdot \dot{u}_2 = i_2$$

$$u_1 = u_2$$

$$i_0 = i_1 + i_2$$

$$u_0 = R \cdot i_0 + u_1$$

$$\dot{u}_1 = \dot{u}_2$$

Algorithmic steps

- Differentiation of constrained equations
- Choose u_2 as dummy-state and u_2' as dummy-derivative
- Extracting underlying ODE (DAE of index 1)

⇒ **ODE with 6 equations and 6 unknowns**

- Check initial condition

$$\mathbf{x} = [u_1]$$

$$\mathbf{y} = \begin{bmatrix} i_0 \\ i_1 \\ i_2 \\ u_2 \\ u_2' \end{bmatrix}$$

$$\mathbf{z} = \begin{bmatrix} \dot{u}_1 \\ i_0 \\ i_1 \\ i_2 \\ u_2 \\ u_2' \end{bmatrix}$$

State Selection in Modelica

■ Influence default state selection mechanism

- Attribute `StateSelect stateSelect = StateSelect.default;`

- Possible choices:

- | | |
|---------|--|
| never | - Do not use as state at all |
| avoid | - Use as state, if it cannot be avoided (but only if variable appears differentiated and no other potential state with attribute default, prefer, or always can be selected) |
| default | - Use as state if appropriate, but only if variable appears differentiated |
| prefer | - Prefer it as state over those having the default value (also variables can be selected, which do not appear differentiated) |
| always | - Do use it as a state |

Initialization of Dynamic Models

Initialization of “free” state variables

- Transformed DAE after index-reduction
- States can be chosen at start time
 - same number of additional equations and “free” states

$$\underline{0} = \underline{f}(t, \dot{\underline{x}}(t), \underline{x}(t), \underline{y}(t), \underline{u}(t), \underline{p})$$



$$\underline{0} = \underline{f}(t, \underline{z}(t), \underline{x}(t), \underline{u}(t), \underline{p}), \quad \underline{z}(t) = \begin{pmatrix} \dot{\underline{x}}(t) \\ \underline{y}(t) \end{pmatrix}$$



$$\underline{z}(t) = \begin{pmatrix} \dot{\underline{x}}(t) \\ \underline{y}(t) \end{pmatrix} = \underline{g}(t, \underline{x}(t), \underline{u}(t), \underline{p})$$



$$\dot{\underline{x}}(t) = \underline{h}(t, \underline{x}(t), \underline{u}(t), \underline{p})$$

$$\underline{y}(t) = \underline{k}(t, \underline{x}(t), \underline{u}(t), \underline{p})$$

Initialization of parameters

- Determine parameter settings
- Parameters can be calculated at start time
 - same number of additional equations and “free” parameters

Initialization mechanism in Modelica

- attribute start
- initial equation section
 - attribute fixed for parameters

Example: 3-Phase Electrical System

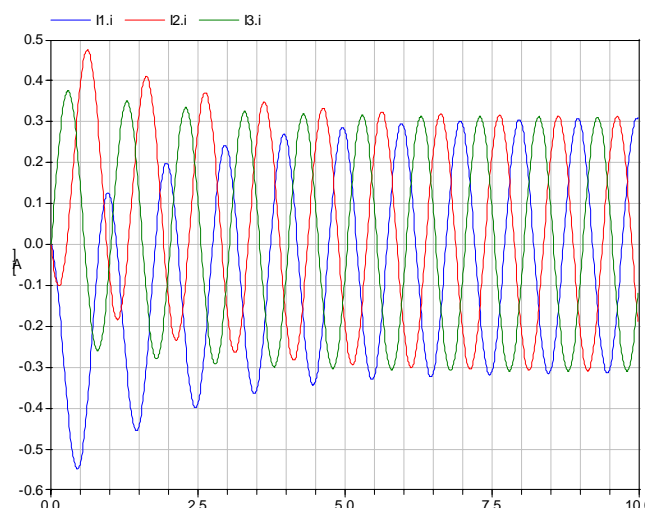
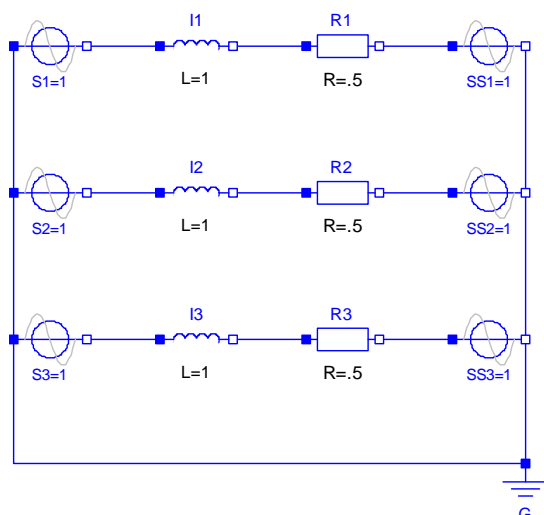

Steady-state initialization?

- States I1.i, I2.i, I3.i are not constant at initial time!
- Here: Initial values set to 0 (standard settings, attribute start)
- Transformation to rotating reference system necessary

Example: 3-Phase Electrical System

Park-Transformation to rotating reference system:

- Write states as vector $i_{abc}[3] = \{I1.i, I2.i, I3.i\}$
- Park-transformation to dq0-reference frame

$$P = \frac{\sqrt{2}}{\sqrt{3}} \begin{pmatrix} \sin(\omega t) & \sin\left(\omega t + \frac{2\pi}{3}\right) & \sin\left(\omega t + \frac{4\pi}{3}\right) \\ \cos(\omega t) & \cos\left(\omega t + \frac{2\pi}{3}\right) & \cos\left(\omega t + \frac{4\pi}{3}\right) \\ \frac{1}{\sqrt{2}} & \frac{1}{\sqrt{2}} & \frac{1}{\sqrt{2}} \end{pmatrix}$$

$$i_{dq0} = P \cdot i_{abc}$$

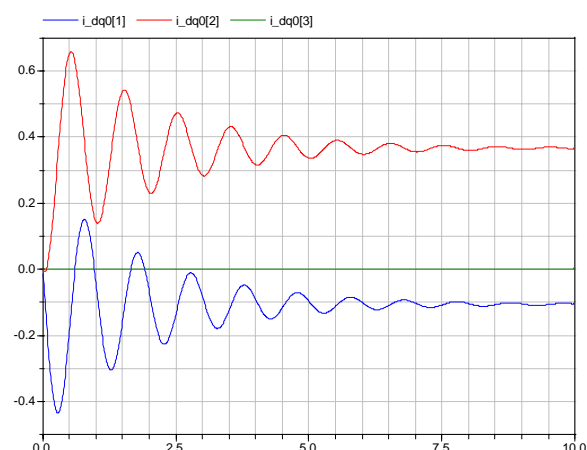

Example: 3-Phase Electrical System Initialize States

```

model Test3PhaseSystem
  parameter Real shift=0.4;
  Real i_abc[3]={I1.i,I2.i,I3.i};
  Real i_dq0[3];
  ...
  initial equation
    der(i_dq0)={0,0,0};
  equation
    ...
    i_dq0 = P*i_abc;
end Test3PhaseSystem
  
```

Steady-state initialization:

- Derivatives of i_{dq0} are only introduced during initialization
- Differentiation of $i_{dq0} = P \cdot i_{abc}$ necessary
- No higher-index problem

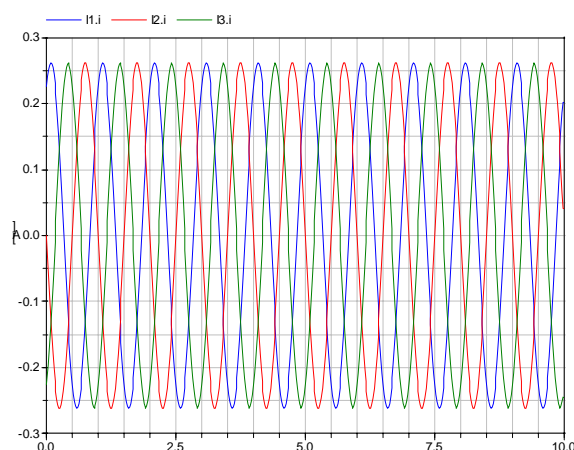

Example: 3-Phase Electrical System

Initialize Parameters

```

model Test3PhaseSystem
  parameter Real shift(fixed=false,start=0.1);
  Real i_abc[3]={I1.i,I2.i,I3.i}, u_abc[3]={S1.v,S2.v,S3.v};
  ...
initial equation
  der(i_dq0)={0,0,0};
  power = -0.12865;
equation
  ...
  u_dq0 = P*u_abc;
  i_dq0 = P*i_abc;
  power = u_dq0*i_dq0;
end Test3PhaseSystem
  
```

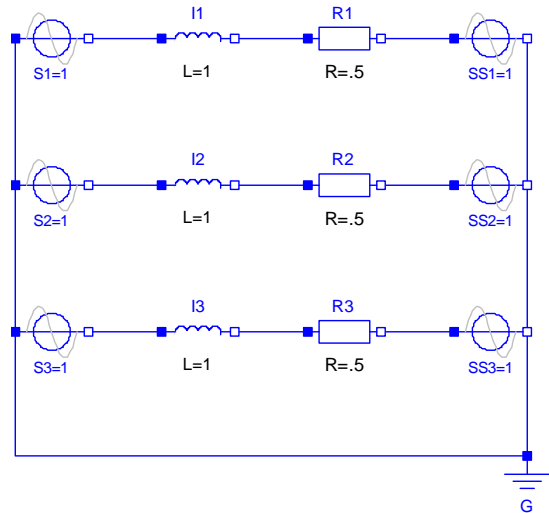

Parameter initialization:

- Non-linear equation, no unique solution
 $power = u_{dq0} * i_{dq0} = -0.12865$
- Attribute `fixed` (default `true`)
- Attribute `start` (default `0`)

Example: 3-Phase Electrical System

Influence State Selection

```

model Test3PhaseSystem
  Real i_abc[3]={I1.i,I2.i,I3.i};
  Real i_dq0[3](each stateSelect=StateSelect.always);
  ...
initial equation
  ...
equation
  ...
  i_dq0 = P*i_abc;
end Test3PhaseSystem
  
```

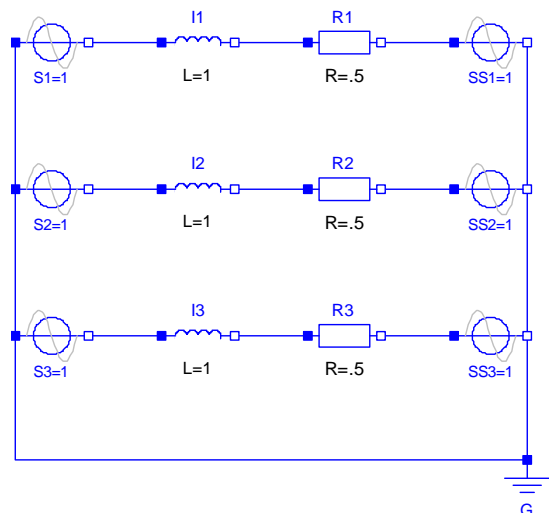

State selection:

- Introduce `i_dq0` as states
 $Real\ di_{dq0}[3];$
 $der(i_{dq0}) = di_{dq0};$
- Constrained equation between states
 must be differentiated
 $i_{dq0} = P * i_{abc};$

Example: 3-Phase Electrical System Introduce Dummy-States/Derivatives

Mathematical formulas to the Park-transformation:
(using trigonometric identities)

$$P = \frac{\sqrt{2}}{\sqrt{3}} \begin{pmatrix} \sin(\omega t) & \sin\left(\omega t + \frac{2\pi}{3}\right) & \sin\left(\omega t + \frac{4\pi}{3}\right) \\ \cos(\omega t) & \cos\left(\omega t + \frac{2\pi}{3}\right) & \cos\left(\omega t + \frac{4\pi}{3}\right) \\ \frac{1}{\sqrt{2}} & \frac{1}{\sqrt{2}} & \frac{1}{\sqrt{2}} \end{pmatrix}$$

$$P \cdot P^T = \begin{pmatrix} 1 & 0 & 0 \\ 0 & 1 & 0 \\ 0 & 0 & 1 \end{pmatrix} \quad P' \cdot P^T = \begin{pmatrix} 0 & \omega & 0 \\ -\omega & 0 & 0 \\ 0 & 0 & 0 \end{pmatrix}$$

$$i_{dq0} = P \cdot i_{abc}$$



$$\frac{d}{dt} i_{dq0} = \omega \cdot \begin{pmatrix} i_{dq0_2} \\ -i_{dq0_1} \\ 0 \end{pmatrix} + P \cdot \frac{d}{dt} i_{abc}$$

Example: 3-Phase Electrical System Introduce Dummy-States/Derivatives

```

model Test3PhaseSystem
  Real i_abc[3]={I1.i,I2.i,I3.i};
  Real i_dq0[3];
  Real di_dq0[3]=2*pi*{i_dq0[2],-i_dq0[1],0} + P*der(i_abc);
  ...
initial equation
  di_dq0={0,0,0};
equation
  ...
  i_dq0 = P*i_abc;
end Test3PhaseSystem
  
```

State selection:

- Introduce di_dq0 as dummy derivative
- Only used during initialization
- No differentiation necessary
- States I1.i, I2.i, I3.i used during simulation

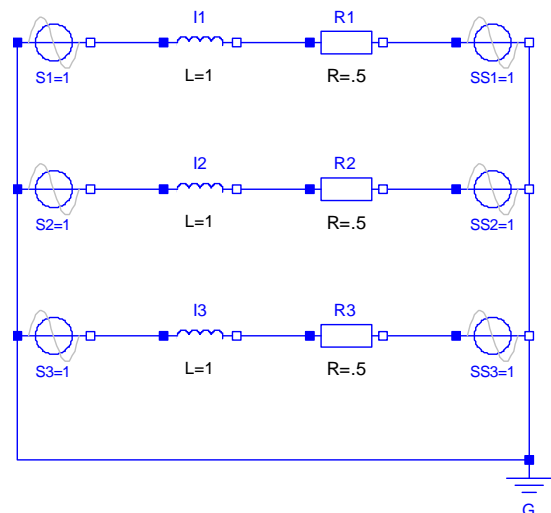

Example: 3-Phase Electrical System Introduce Dummy-States/Derivatives

State selection:

- Introduce di_abc as dummy derivative
- Rewrite inductor equation: $L \cdot di = v$;
- No differentiation necessary
- Efficiency increase during simulation (real-time aspect)

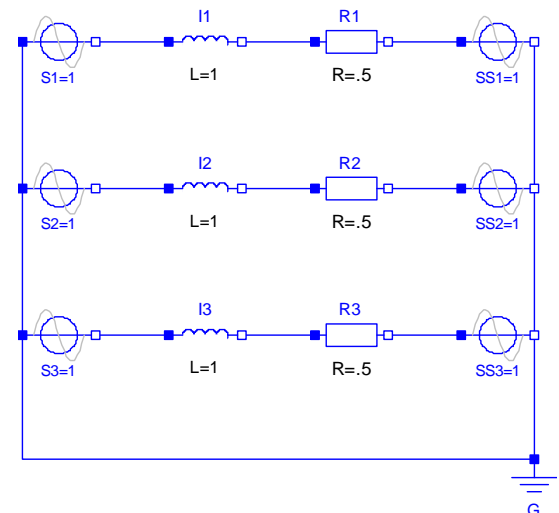

```
model Test3PhaseSystem
```

```
Real i_abc[3]={I1.i,I2.i,I3.i};
```

```
Real di_abc[3]={I1.di,I2.di,I3.di};
```

```
Real i_dq0[3];
```

```
...
```

```
initial equation
```

```
der(i_dq0)={0,0,0};
```

```
equation
```

```
...
```

```
i_dq0 = P*i_abc;
```

```
der(i_dq0)=2*pi*{i_dq0[2],-i_dq0[1],0} + P*di_abc;
```

```
end Test3PhaseSystem
```

2006-09-04

B. Bachmann, FH Bielefeld

Mathematical Aspects of Object-Oriented
Modeling and Simulation

49

Numerical Integration of ODEs/DAEs

Integration methods for ODEs

- Single-step methods
 - explicit and implicit Runge-Kutta formulas
 - fixed and variable step-size
 - Richardson-Extrapolation
 - embedded Runge-Kutta Formulas (Dopri5)
- Multi-step methods
 - explicit and implicit schemes
 - Adams/Bashforth/Moulton formulas
 - BDF-formulas (i.e. DASSL)
 - start-up using single-step methods (events)
- Event handling
 - stop simulation and restart integration

Stability region and stiffness detection

- Linearize the system
- Determine eigenvalues

$$\underline{0} = \underline{f}(t, \underline{\dot{x}}(t), \underline{x}(t), \underline{y}(t), \underline{u}(t), \underline{p})$$



$$\underline{0} = \underline{f}(t, \underline{z}(t), \underline{x}(t), \underline{u}(t), \underline{p}), \quad \underline{z}(t) = \begin{pmatrix} \underline{\dot{x}}(t) \\ \underline{y}(t) \end{pmatrix}$$



$$\underline{z}(t) = \begin{pmatrix} \underline{\dot{x}}(t) \\ \underline{y}(t) \end{pmatrix} = \underline{g}(t, \underline{x}(t), \underline{u}(t), \underline{p})$$



$$\underline{\dot{x}}(t) = \underline{h}(t, \underline{x}(t), \underline{u}(t), \underline{p})$$

$$\underline{y}(t) = \underline{k}(t, \underline{x}(t), \underline{u}(t), \underline{p})$$

2006-09-04

B. Bachmann, FH Bielefeld

Mathematical Aspects of Object-Oriented
Modeling and Simulation

50

Stability Analysis of Runge-Kutta Methods

ODE problem: $\dot{\underline{x}}(t) = \underline{f}(t, \underline{x}(t))$

describing disturbance: $\underline{y}'(t) = J(t) \cdot \underline{y}(t), \quad J(t) = \frac{\partial f}{\partial \underline{x}}(t, \underline{x})$

Euler integration:
(J constant) $\underline{y}_{m+1} = \underline{y}_m + \Delta t \cdot J \cdot \underline{y}_m = R(\Delta t \cdot J) \cdot \underline{y}_m$
 $R(z) = 1 + z$

eigenvector \underline{y}_0
eigenvalue λ $\underline{y}_m = [R(\Delta t \cdot \lambda)]^m \cdot \underline{y}_0$

bounded solution, iff $|R(\Delta t \cdot \lambda)| \leq 1, \lambda$ eigenvalue of J

Stability Analysis of Runge-Kutta Methods

Dahlquist test equation: $y' = \lambda \cdot y, \quad y_0 = 1, \quad z = \Delta t \cdot \lambda$

Stability function $R(z)$ is corresponding numerical solution at $t + \Delta t$:

Runge-Kutta method
(order=p): $R(z) = 1 + \frac{z}{1!} + \dots + \frac{z^p}{p!} + O(z^{p+1})$

Runge-Kutta method
(order=s, explicit, s_stage): $R(z) = 1 + \frac{z}{1!} + \dots + \frac{z^s}{s!}$

Dopri5
(order=5, explicit, 6_stage): $R(z) = 1 + \frac{z}{1!} + \dots + \frac{z^5}{5!} + \frac{z^6}{600}$

bounded solution, iff $|R(\Delta t \cdot \lambda)| \leq 1, \lambda$ eigenvalue of J

Stability Region for Explicit Runge-Kutta Methods

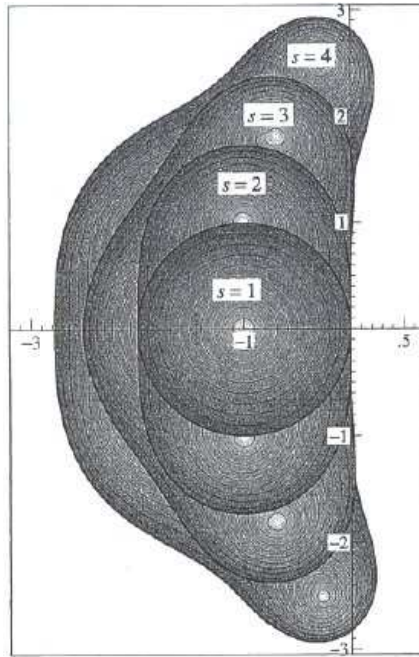

Fig. 2.1. Stability domains for explicit Runge-Kutta methods of order $p = s$

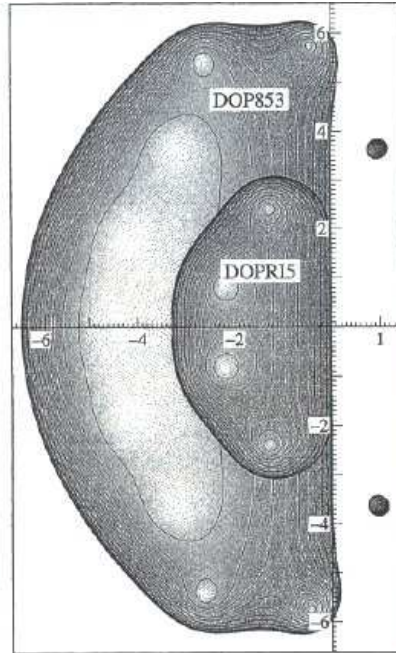

Fig. 2.2. Stability domains for DOPRI methods

Stability Region for Implicit Runge-Kutta Methods

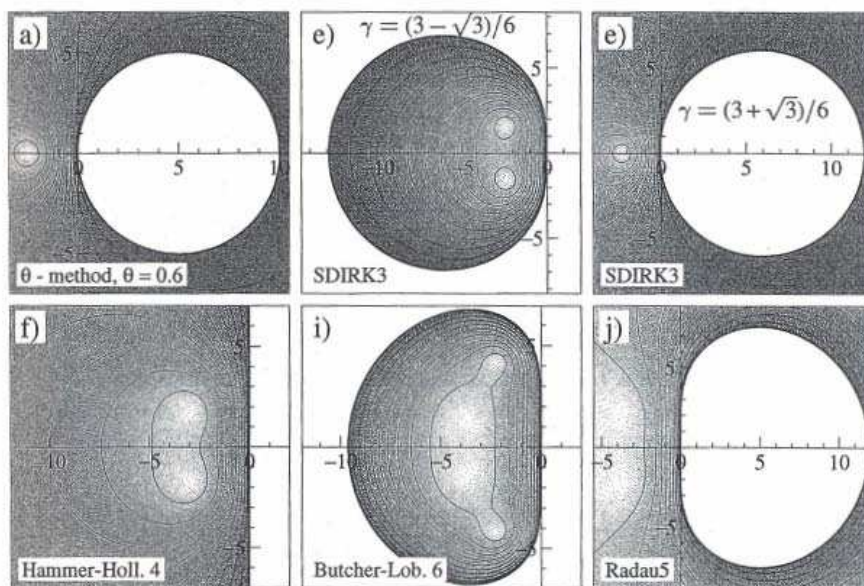

Fig. 3.1. Stability domains for implicit Runge-Kutta methods

Stability Region for Adams-Multi-Step Methods

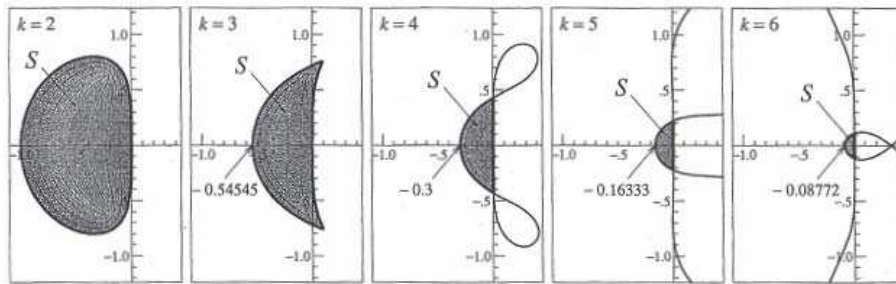

Fig. 1.2. Stability domains for explicit Adams methods

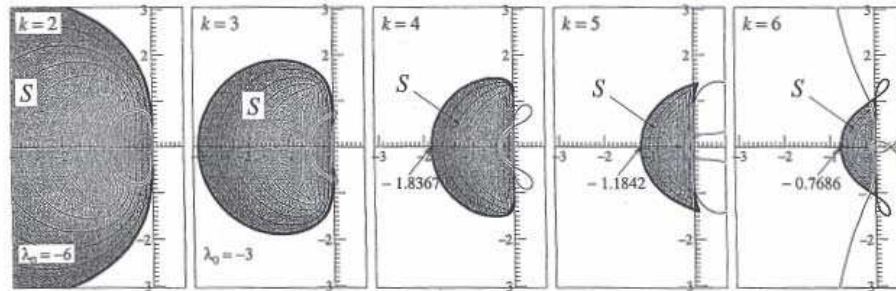

Fig. 1.3. Stability domains of implicit Adams methods, compared to those of the explicit ones

Stability Region for BDF – Methods (i.e. DASSL)

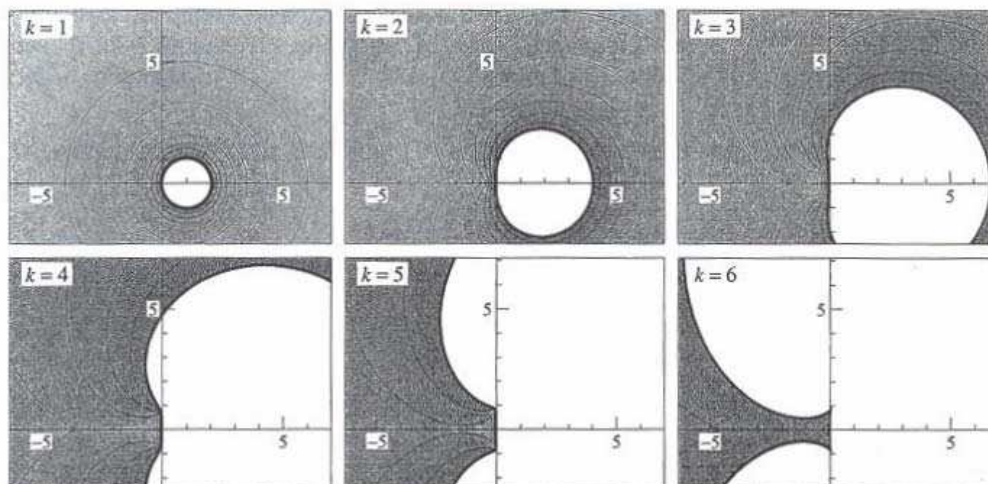

Fig. 1.6. Root locus curves and stability domains of BDF methods

Numerical Examples (Stability Region)

■ Curtiss & Hirschfelder

- Transition phase at the initial point
- Determine maximal fixed step-size

$$y' = -50(y - \cos(t)), \text{ eigenvalue } \lambda = -50$$

$\Delta t = 0.039$: (explicit Euler)

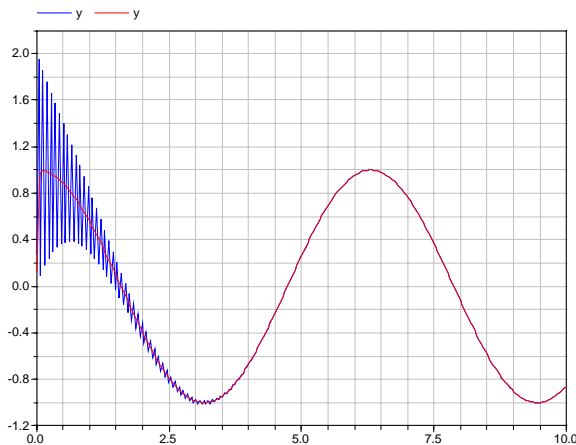

2006-09-04
B. Bachmann, FH Bielefeld

$\Delta t = 0.04$: (explicit Euler)

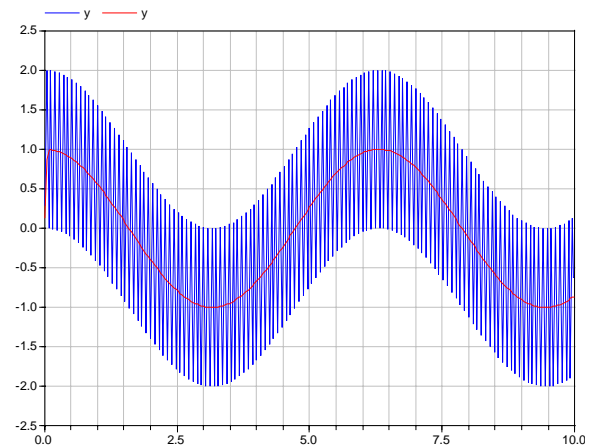

Mathematical Aspects of Object-Oriented
Modeling and Simulation

57

Numerical Examples (Stability Region and Stiffness)

■ Van der Pol

- Simple nonlinear equation describing electrical systems
- Stiff system, if $\varepsilon \gg 1$.

$$\begin{aligned} y_1' &= y_2 \\ y_2' &= \varepsilon(1 - y_1^2)y_2 - y_1 \end{aligned} \quad \text{mit } J(t) = \begin{pmatrix} 0 & 1 \\ -2\varepsilon y_1 y_2 - 1 & \varepsilon(1 - y_1^2) \end{pmatrix}$$

$\varepsilon = 2$:

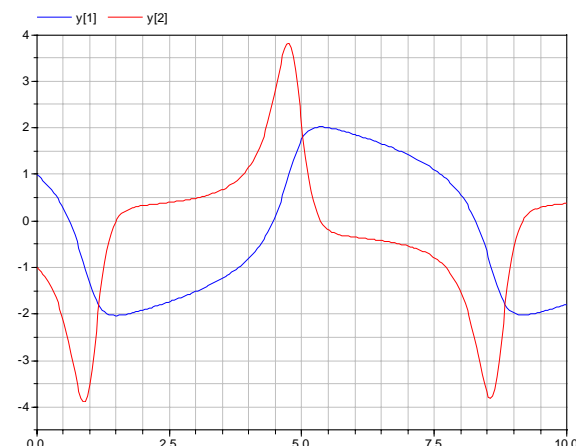

2006-09-04
B. Bachmann, FH Bielefeld

$\varepsilon = 8$:

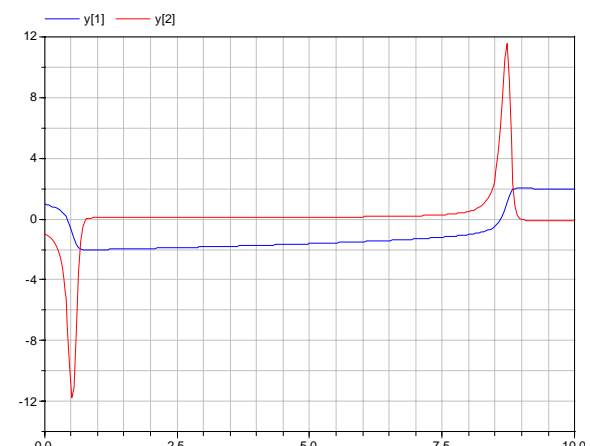

Mathematical Aspects of Object-Oriented
Modeling and Simulation

58

Determine Stability Region (Van der Pol equation)

Linearize the system at initial time

- Calculate the Jacobians
- Read matrix into Matlab
- Determine the eigenvalues
- Calculate maximal step-size

$$\begin{aligned} \dot{x}(t) &= \underline{h}(t, \underline{x}(t), \underline{u}(t), \underline{p}) & \longrightarrow & \dot{x}(t) = A\underline{x}(t) + B\underline{u}(t) \\ y(t) &= \underline{k}(t, \underline{x}(t), \underline{u}(t), \underline{p}) & & y(t) = C\underline{x}(t) + D\underline{u}(t) \end{aligned}$$

```
>> A = tloadlin
>c:\...\dslin.mat loaded.
A =      0      1.0000
     39.0000      0
>> l=eig(A)
l =      6.245
     -6.245
>>delta_t=2/6.245
delta_t = 0.3203
```

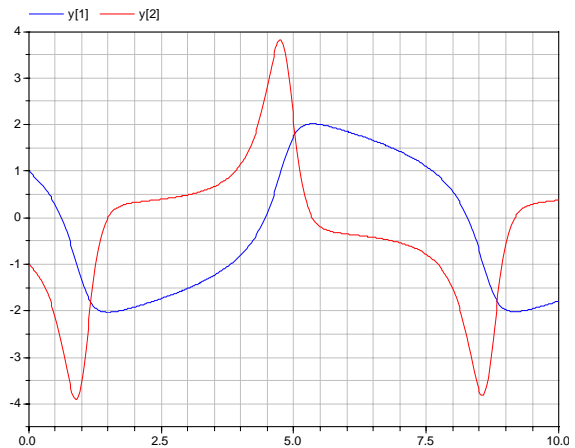

Determine Stability Region (Van der Pol equation)

bounded solution, iff

$$|R(\Delta t \cdot \lambda)| \leq 1, \quad \lambda \text{ eigenvalue of } J$$

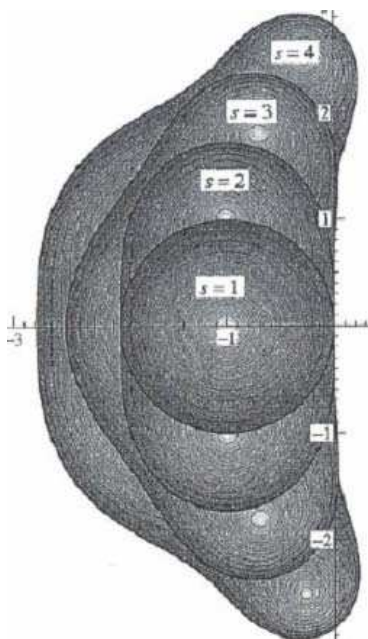

explicit Euler method: $R(z) = 1 + z$

$$|R(\Delta t \cdot \lambda)| = |1 + \Delta t \cdot \lambda| = \left| \begin{pmatrix} 1 \\ 0 \end{pmatrix} + \Delta t \begin{pmatrix} x \\ y \end{pmatrix} \right| \leq 1$$

$$\Leftrightarrow (1 + \Delta t \cdot x)^2 + (\Delta t \cdot y)^2 \leq 1$$

$$\Leftrightarrow \Delta t^2 (x^2 + y^2) + 2 \cdot \Delta t \cdot x \leq 0$$

$$\Leftrightarrow \Delta t \leq -\frac{2 \cdot x}{x^2 + y^2}$$

Determine Stability Region (Van der Pol equation)

- Calculate eigenvalues during simulation

```

model VanDerPol
  import Matrices.eigenValues;
  import Vectors.norm;
  parameter Real epsilon=2;
  Real y[2] (start={1,-1});
  Real eigenV[2,2];
  Real delta_t;
equation
  der(y[1]) = y[2];
  der(y[2]) = epsilon*(1 - y[1]*y[1])*y[2] - y[1];
  eigenV=eigenValues(
    [
      0, 1;
      -2*epsilon*y[1]*y[2]-1, epsilon*(1-y[1]*y[1])]);
  delta_t=max(-2*eigenV[1,1]/(eigenV[1,:]*eigenV[1,:]),
    -2*eigenV[2,1]/(eigenV[2,:]*eigenV[2,:]));
end VanDerPol;
    
```

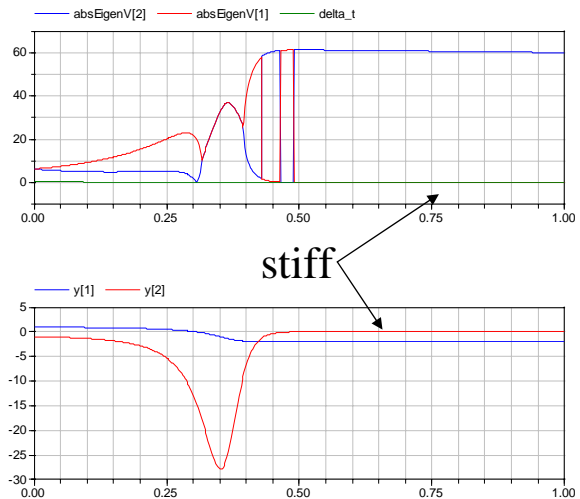

$$\implies \Delta t_{\max} = 0.0326524$$

Event Handling Motivation and Numerical Issues

- Need of discontinuous components

- Detailed modeling too complex
- Model parameters are not known for detailed models
- Non-ideal approximation leads to stiff systems
- Speed up simulation time (omit stiffness)

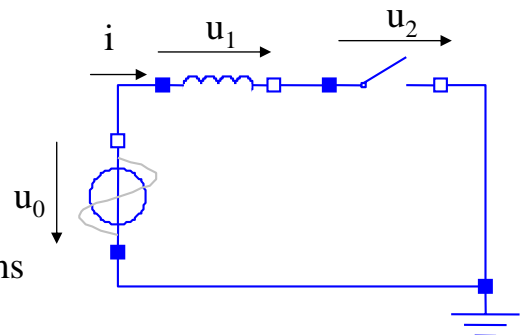

- Numerical problems at events

- ODE solver based on polynomial approximation
- Usually some signals are not continuous or differentiable
- Fixed step size leads to bad approximation of events
- Varying higher-index problems can occur at events

Example: Non-Ideal Switch Stiffness Problem

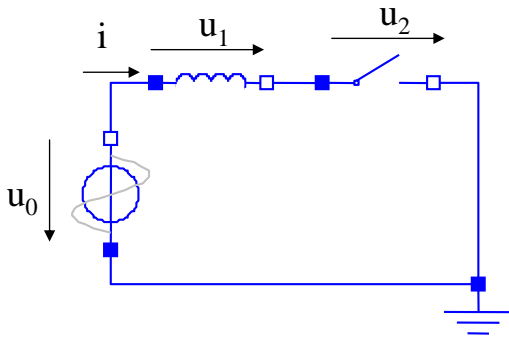

$$\begin{aligned}
 u_0 &= A \sin(\omega t) & \longrightarrow & \quad L \frac{di}{dt} = A \sin(\omega t) - R i \\
 u_2 &= R i \\
 L \frac{di}{dt} &= u_1 \\
 u_0 &= u_1 + u_2
 \end{aligned}$$

$$\lambda = -\frac{R}{L}$$

Non-ideal switch:

closed: $u_2 = R i, R=1e-5$

open: $G i = u_2, G=1e-5$

$$\begin{aligned}
 u_0 &= A \sin(\omega t) & \longrightarrow & \quad L \frac{di}{dt} = A \sin(\omega t) - \frac{i}{G} \\
 i &= G u_2 \\
 L \frac{di}{dt} &= u_1 \\
 u_0 &= u_1 + u_2
 \end{aligned}$$

$$\lambda = -\frac{1}{L \cdot G}$$

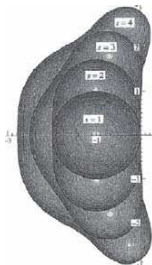

If the switch is open, system is stiff!

Continuous Variables and the if-Statement

State events

- zero-crossing function
- i.e. bi-section method between adjacent time points

$y = \text{if } u > 0 \text{ then } 1 \text{ else } -1;$

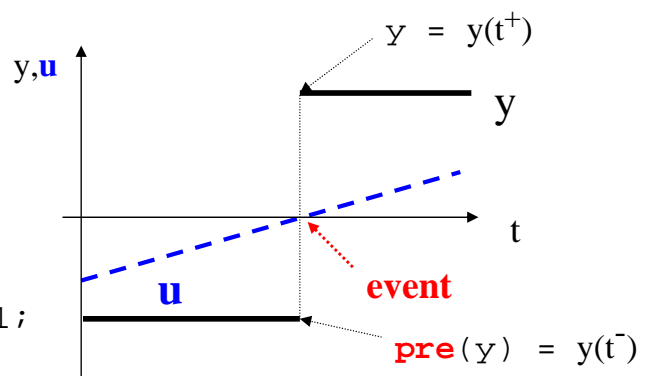

Time events

- no zero-crossing function necessary
- special treatment during compile time possible

$y = \text{if } \text{time} > .5 \text{ then } 1 \text{ else } -1;$

Principle Strategy at Events (Simple Example)

- **Standard-solution method**
 - Stop integration at event time
 - Do necessary adjustments
 - change input signals and/or discrete variables, re-initialize states
 - Restart integration routine
 - start-up of multi-step methods, initial step-size

- **Continuous time integration between events**
 - Appropriate step size control

- **Store signals twice at event time**
 - Variables before and after the event

```

model StateEvent
  import Modelica.Math.sin;
  Real u;
  Real y;
equation
  u = sin(time);
  y = if u<0 then 1 else -1;
end StateEvent
  
```

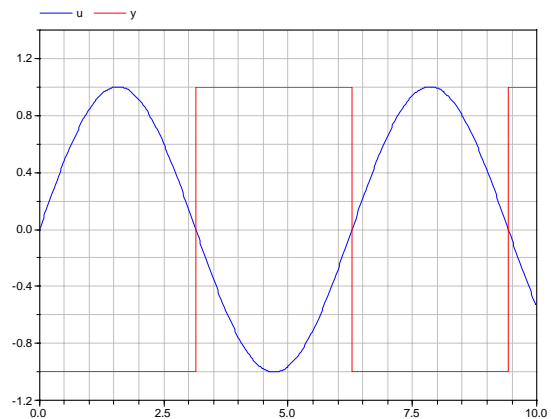

Real-Time Solution to Events

- **One-step method with fixed step-size**
 - Detect event (u crosses 0)
 - Approximate exact event time
 - use (linear) polynomial approximation of the signal
 - Restart integration routine
 - combine two equidistant steps

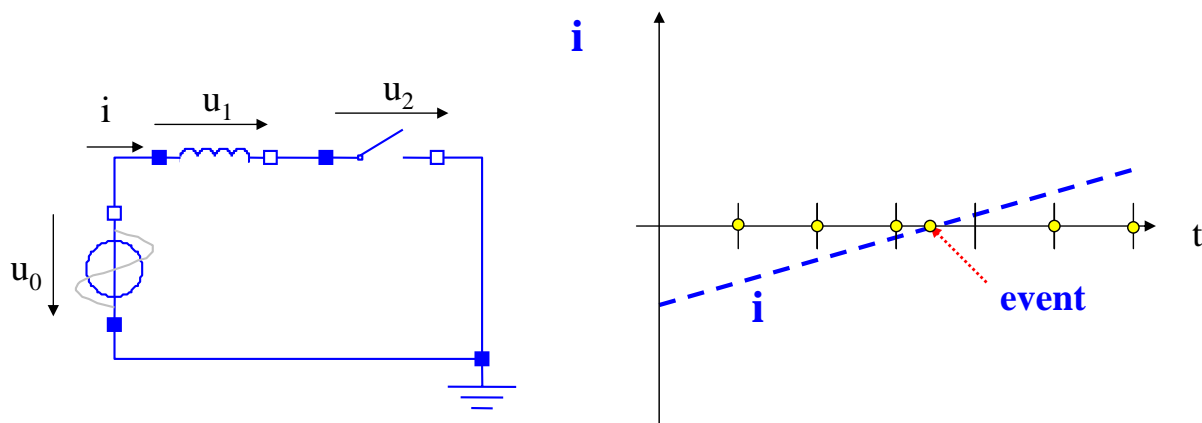

Influence Event-Handling

```

model SmoothEvent
  constant Real pi=Modelica.Constants.pi;
  Real x,z,y,u;
equation
  x = if time<pi/2 then cos(time) else pi/2-time;
  y = noEvent( if time<pi/2 then cos(time) else pi/2-time);
  z = smooth(1,if time<pi/2 then cos(time) else pi/2-time);
  u = smooth(1, noEvent(if time<pi/2 then cos(time) else pi/2-time));
end SmoothEvent
  
```

Semantical interpretation:

- Equation for x: triggers event
- Equation for y: no event handling
- Equation for z: may trigger event
 - may depend on the integration method
- Equation for u: no event handling

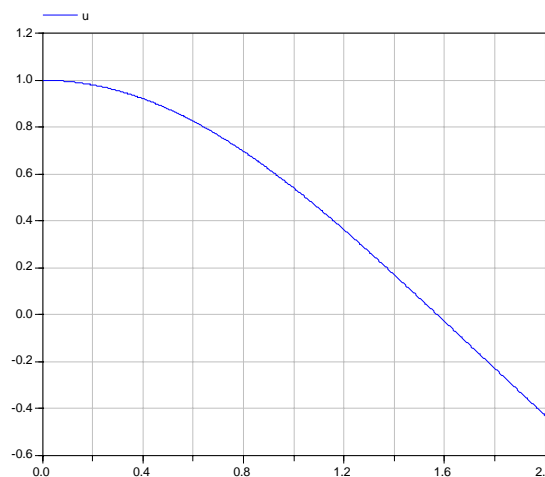

Sorting Equations Including if-Equations

■ Modelica model:

- Differential equations, algebraic equations

$$\underline{0} = \underline{f}\left(\underline{t}, \underline{\dot{x}}(t), \underline{x}(t), \underline{y}(t), \underline{u}(t), \underline{p}\right)$$

- if-equations

- $y = \mathbf{if} \langle \text{cond} \rangle \mathbf{then} \langle \text{expr1} \rangle \mathbf{else} \langle \text{expr2} \rangle;$

■ Mathematical view:

- $\langle \text{cond} \rangle c$ is a boolean expression
 - may depend on a state or time event (Causality)
- An if-equation is treated as one equation depending on $\langle \text{cond} \rangle c$ and the variables w_1, \dots, w_n in $\langle \text{expr1} \rangle$ and v_1, \dots, v_m in $\langle \text{expr2} \rangle$

$$0 = g\left(c, w_1, \dots, w_n, v_1, \dots, v_m, \underline{p}\right)$$

Example: Ideal Electrical Switch

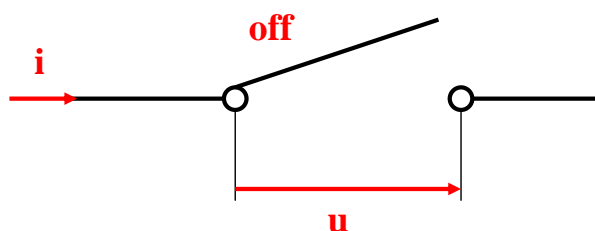

The ideal switch is described by the following two equations:

$$\text{off} = \text{true}: \quad \mathbf{i} = \mathbf{0}$$

$$\text{off} = \text{false}: \quad \mathbf{u} = \mathbf{0}$$

Corresponding Modelica code:

```
0 = if off then i else u;
```

Equivalent description (**off = 0/1**):

$$0 = \text{off} \cdot i + (1 - \text{off}) \cdot u$$

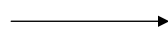

$$0 = f(i, u, \text{off})$$

Example: Ideal Electrical Switch

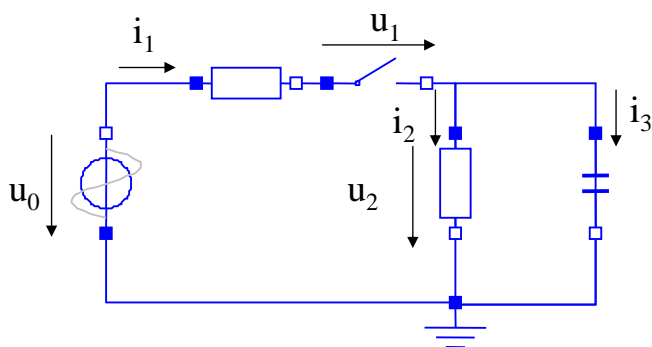

$$u_0 = A \sin(\omega t)$$

$$u_0 = R_1 \cdot i_1 + u_1 + u_2$$

$$0 = \text{off} \cdot i_1 + (1 - \text{off}) \cdot u_1$$

$$i_2 = R_2 / u_2$$

$$i_3 = i_1 - i_2$$

$$C \dot{u}_2 = i_3$$

Linear system of two equations:

$$u_0 = R_1 \cdot i_1 + u_1 + u_2$$

$$0 = \text{off} \cdot i_1 + (1 - \text{off}) \cdot u_1$$



$$\begin{bmatrix} R_1 & 1 \\ \text{off} & (1 - \text{off}) \end{bmatrix} \cdot \begin{bmatrix} i_1 \\ u_1 \end{bmatrix} = \begin{bmatrix} u_0 - u_2 \\ 0 \end{bmatrix}$$

Two possible solutions:

$$\text{off} = 1 : \quad i_1 = 0$$

$$u_1 = u_0 - u_2$$

$$\text{off} = 0 : \quad u_1 = 0$$

$$i_1 = (u_0 - u_2) / R_1$$

Example: Ideal Electrical Switch

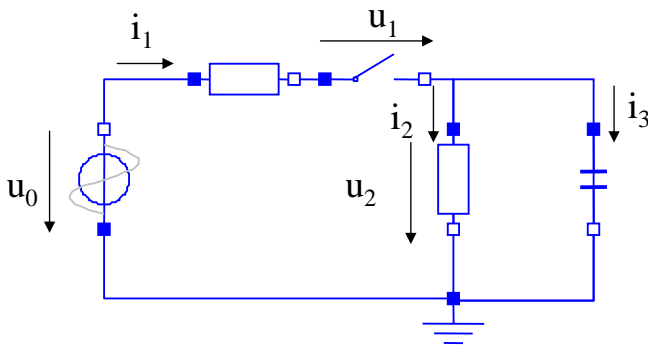

$$u_0 = A \sin(\omega t)$$

$$u_0 = R_1 \cdot i_1 + u_1 + u_2$$

$$0 = \text{off} \cdot i_1 + (1 - \text{off}) \cdot u_1$$

$$i_2 = R_2 / u_2$$

$$i_3 = i_1 - i_2$$

$$C \dot{u}_2 = i_3$$

Unrealistic behavior :

- The current can not jump to zero
- Usually an arc keeps current flowing
- Current must be close to zero
- Additional logic necessary
 - needs **when**-equations (example will be continued)

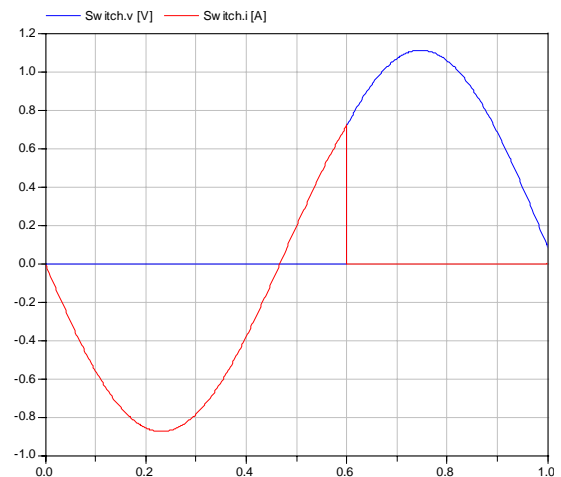

Algebraic Loops Involving Integer and/or Boolean Variables

```

model AlgebraicLoopBoolean
  Boolean a(start=true);
  Boolean b;
  Real u;
  Real v;
equation
  u = sin(time);
  v = sin(2*time);
  b = not pre(a) and abs(u)>0.5;
  a = not b and abs(v)>0.5;
end AlgebraicLoopBoolean
    
```

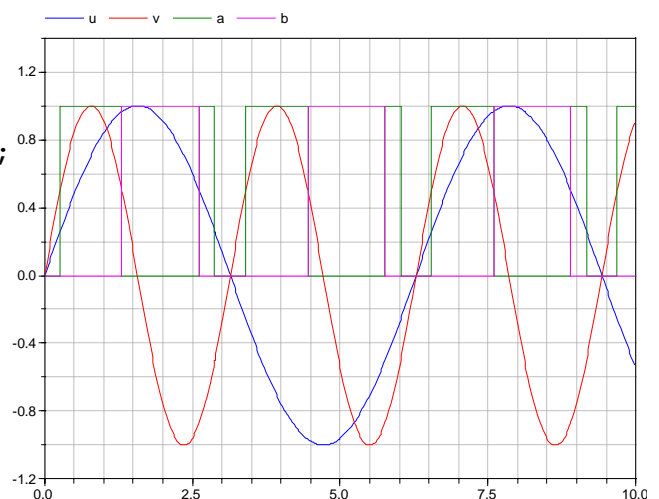

- Algebraic loops involving boolean variables must be handled by the user!
- Break loops using the **pre** operator

Discrete Variables and the when-Statement

Additional equations can be declared at an event using the **when**-statement. These equations are de-activated during the continuous integration.

```
when <condition> then
  <equations>
end when;
```

When <condition> becomes true, <equations> are calculated.

Equivalent formulation:

```
if edge(<condition>) then
  <equations>
end if;
```

<condition> may not depend on a **noEvent()** Operator. Therefore, only at event points the equations within the when clause are evaluated

Re-writing State Events to Time Events

```
model HandleEvents
  constant Real PI=Modelica.Constants.pi;
  Real u;
  Real y;
  Boolean flag(start=false);
equation
  u = Modelica.Math.sin(time);
  when sample(PI,PI) then
    flag = not pre(flag);
  end when;
  y = if flag then 1 else -1;
  //y = if u<0 then 1 else -1;
end HandleEvents
```

Real-time efficiency:

- If possible use time-events instead of state-events

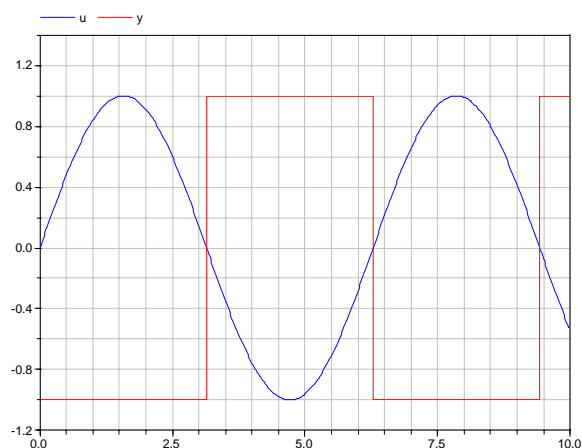

- Modelica model:

- Differential equations, algebraic equations, and if-equations

$$\underline{0} = \underline{f}(t, \underline{\dot{x}}(t), \underline{x}(t), \underline{y}(t), \underline{u}(t), \underline{p})$$

- Discrete equations only active at events

- **when** <cond> **then** <equations> **end when**;

- Mathematical view:

- Same number of equations and unknowns at each time point
- Different number of equations and unknowns during event

- Algorithmic strategy:

- Sorting is based on all equations

Example: Digital Controller

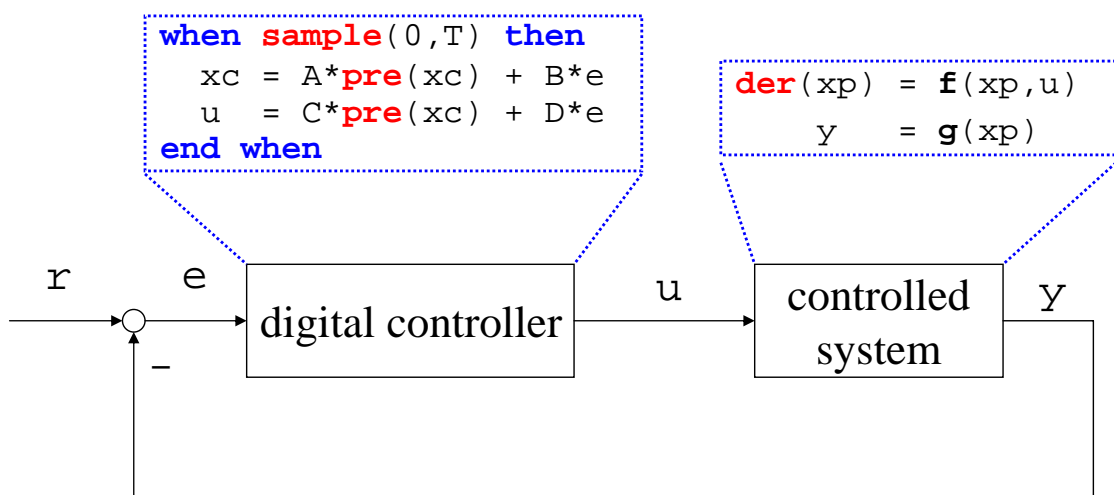

```

y := g(xp);
e := r - y;
when sample(0,T) then
  xc := A*pre(xc) + B*e;
  y := C*pre(xc) + D*e;
end when
der(xp) := f(xp,u);
    
```

Order of evaluation is correct for the sample time points as well as during continued time integration!

(xp and **pre**(xc) are known)

Sorting Equations of Hybrid Models

- **IMPORTANT:**

Each discrete variable is determined by one equation

– Example:

```
when h1>0 then
  openValve = true;
end when;
```

```
when h2<2 then
  openValve = false;
end when;
```

– Not allowed since two equations for one variable openValve

– Combine conditions $h1>0$ and $h2<2$

Sorting Equations of Hybrid Models

Re-writing event equations

```
when h1>0 or h2<2 then
  openValve = if edge(h1 > 0) then true else false;
end when;
```

Semantical interpretation:

If one condition becomes true, (i.e. $h1 > 0$), no further event will happen not even when the second condition ($h2 < 2$) becomes true.

Boolean expression ($h1>0$ or $h2<2$) will not change anymore!

This is not the desired logic!

Sorting Equations of Hybrid Models

Desired logic can be described by

```
when {h1>0, h2<2} then
  openValve = if edge(h1 > 0) then true else false;
end when;
```

or even shorter:

```
when {h1>0, h2<2} then
  openValve = edge(h1 > 0);
end when;
```

```
when {expr1, expr2, expr3, ...} then
```

Semantical interpretation:

- Triggers an event, if one of the listed boolean expression becomes true

Example: Difference of „or“ and {...,...}

```
model whendemo3
  parameter Real A=1.5, w=6;
  Real u1, u2;
  Boolean b1, b2;
equation
  u1 = A*sin(w*time) + 1.e-10;
  u2 = A*cos(w*time);
  when u1 > 0 or u2 > 0 then
    b1 = not pre(b1);
  end when;
  when {u1 > 0, u2 > 0} then
    b2 = not pre(b2);
  end when;
end whendemo3;
```

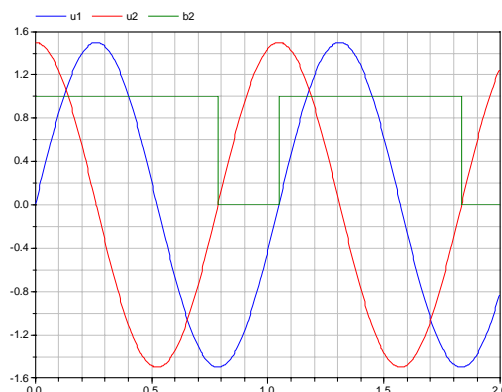
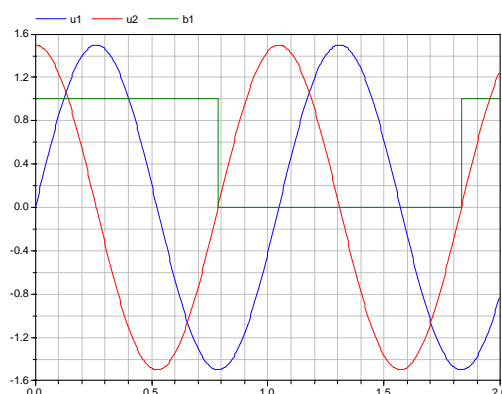

Example: Ideal Electrical Switch (continued)

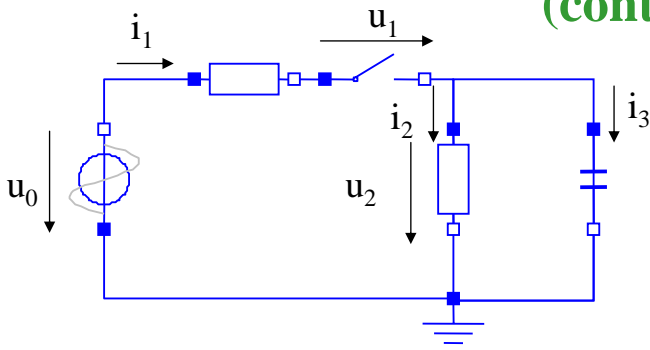

$$u_0 = A \sin(\omega t)$$

$$u_0 = R_1 \cdot i_1 + u_1 + u_2$$

$$0 = \text{off} \cdot i_1 + (1 - \text{off}) \cdot u_1$$

$$i_2 = R_2 / u_2$$

$$i_3 = i_1 - i_2$$

$$C \dot{u}_2 = i_3$$

Introduce additional logic :

- Algebraic loop with boolean variable

```

when (time>t0) then
  sign_i = if (i1>0) then 1 else -1;
end when;
when (time>t0 and sign_i*i1<0) then
  off = true;
end when;
0 = if pre(off) then i1 else u1;
    
```

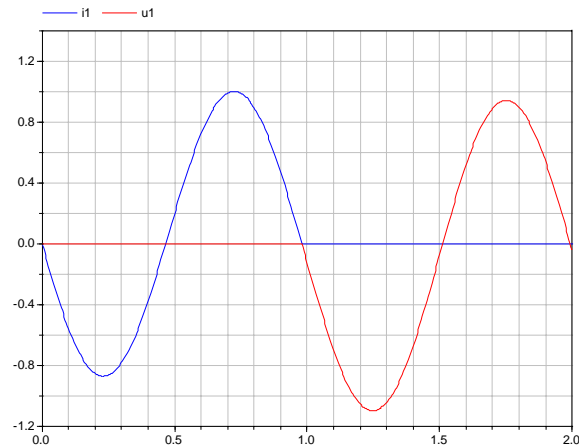

Example: Ideal Electrical Switch (continued)

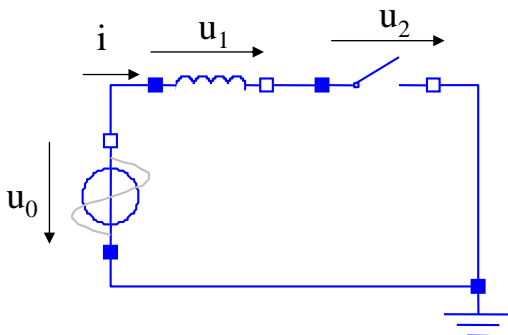

$$u_0 = A \sin(\omega t)$$

$$0 = \text{off} \cdot i + (1 - \text{off}) \cdot u_2$$

$$L \frac{di}{dt} = u_1$$

$$u_0 = u_1 + u_2$$

Causality (off = 0/1):

- i is a state and is therefore known

$$u_2 = \frac{-\text{off} \cdot i}{1 - \text{off}}$$

Only solvable, iff off=0

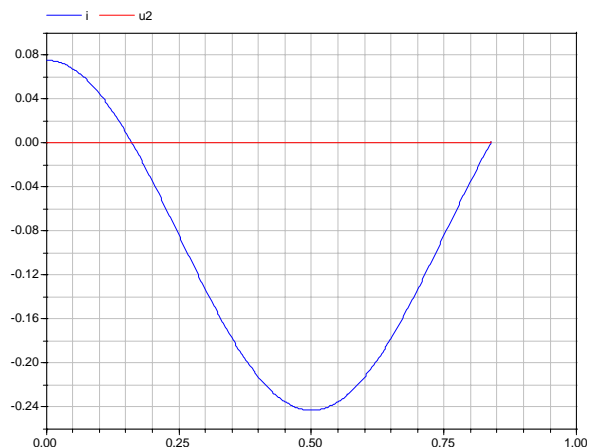

Example: Ideal Electrical Switch (continued)

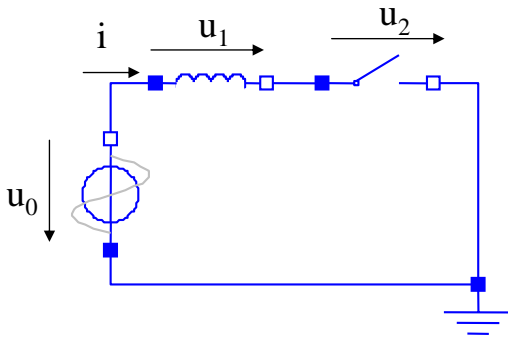

$$u_0 = A \sin(\omega t)$$

$$0 = \text{off} \cdot \frac{di}{dt} + (1 - \text{off}) \cdot u_2$$

$$L \frac{di}{dt} = u_1$$

$$u_0 = u_1 + u_2$$

Varying higher-index problem

$$\text{off} = 0 : u_2 = 0 \quad \text{index}=1$$

$$\text{off} = 1 : i = 0 \quad \text{index}=2$$

$$\frac{di}{dt} = 0$$

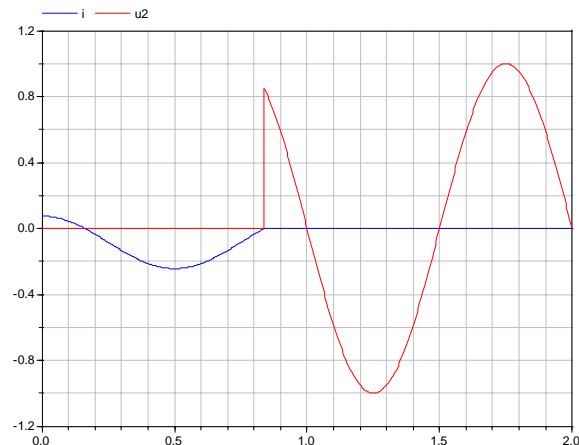

Example: 3-Phase Electrical System (continued)

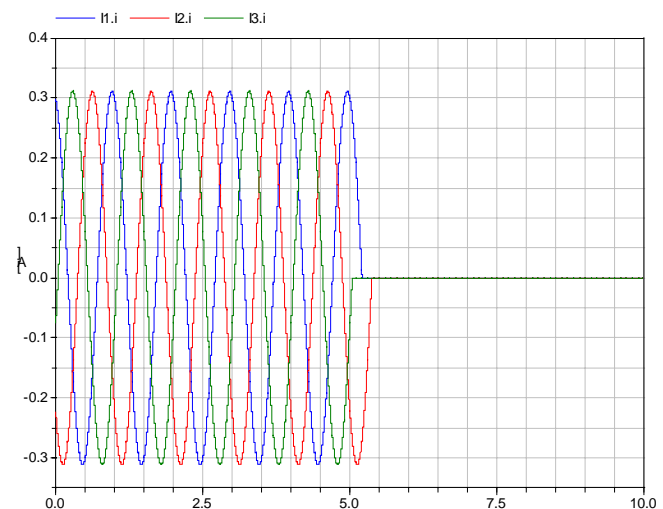
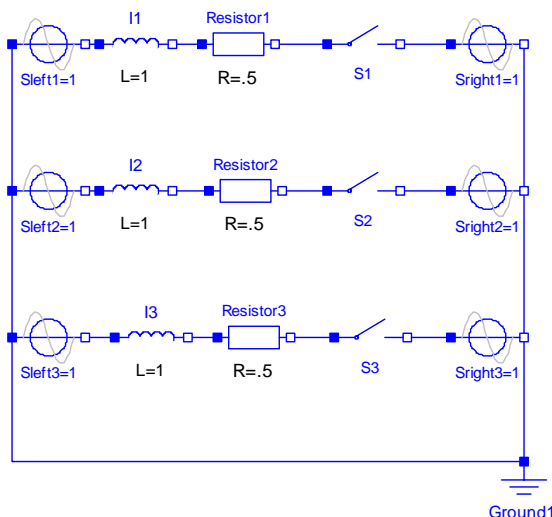

Switch works also for the 3-Phase electrical system

- Introducing dq0-reference frame still very efficient
- i_{dq0} used as state
- Initialization: $\text{der}(i_{dq0}) = \{0, 0, 0\}$;

Numerical Issues

- **Standard-solution method**
 - Stop integration at event time
 - Do necessary adjustments
 - Restart integration routine
- **Due to numerical errors the system can get into a non-physical state**
 - Height h is negative in the bouncing ball example
- **Solution to this problem**
 - Changes in the settings (accuracy) for the solver routine may help
 - Different integration methods may lead to different results
 - Adapt logic to circumvent numerical problems (**Most Efficient**)

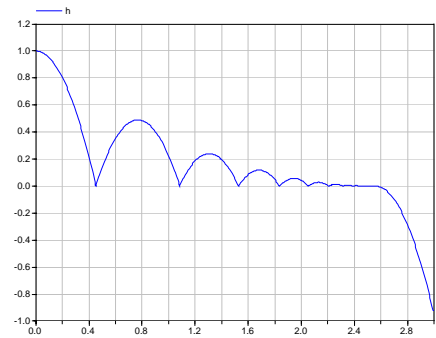
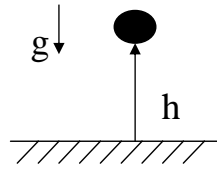

```

model bouncingBall
  parameter Real e=0.7;
  parameter Real g=9.81;
  Real h(start=1);
  Real v;
  equation
    der(h) = v;
    der(v) = -g;
    when h < 0 then
      reinit(v, -e*pre(v));
    end when;
  end bouncingBall;
  
```

Numerical Issues

Solution to the Bouncing Ball

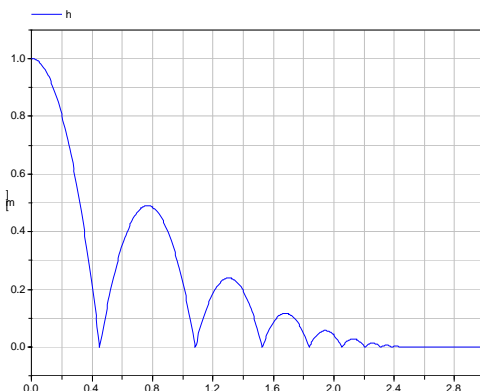
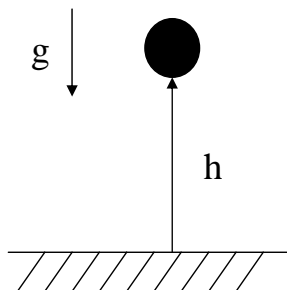

```

model bouncingBall
  parameter Real e=0.7;
  parameter Real g=9.81;
  Real h(start=1);
  Real v;
  Boolean flying(start=true)
  Boolean impact;
  Real v_new;
  equation
    der(h) = v;
    der(v) = if flying then -g else 0;
    impact = h < 0;
    when {impact, h < 0 and v < 0} then
      v_new = if edge(impact) then -e*pre(v)
              else 0;
      flying = v_new > 0;
      reinit(v, v_new);
    end when;
  end bouncingBall;
  
```